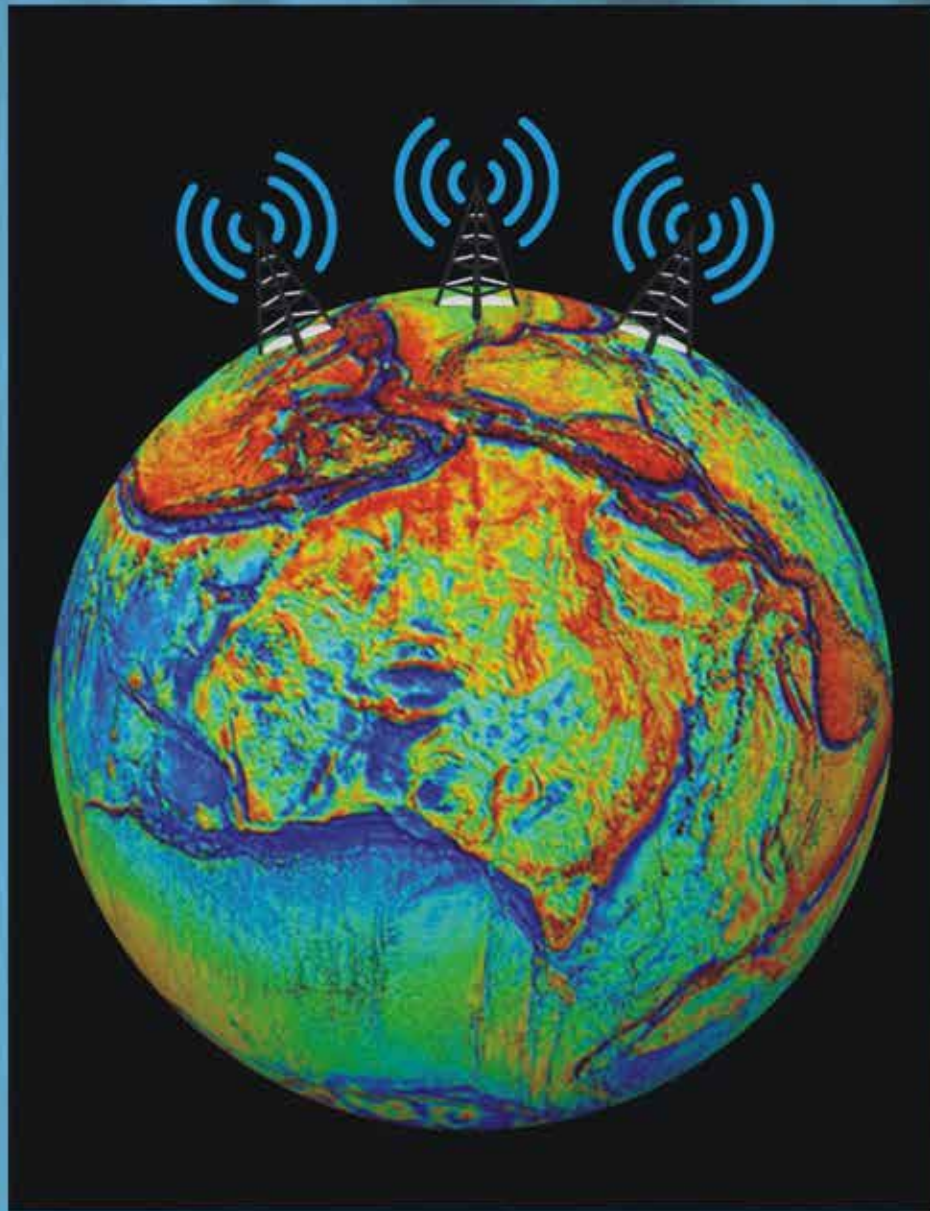


# *Fast*TIMES

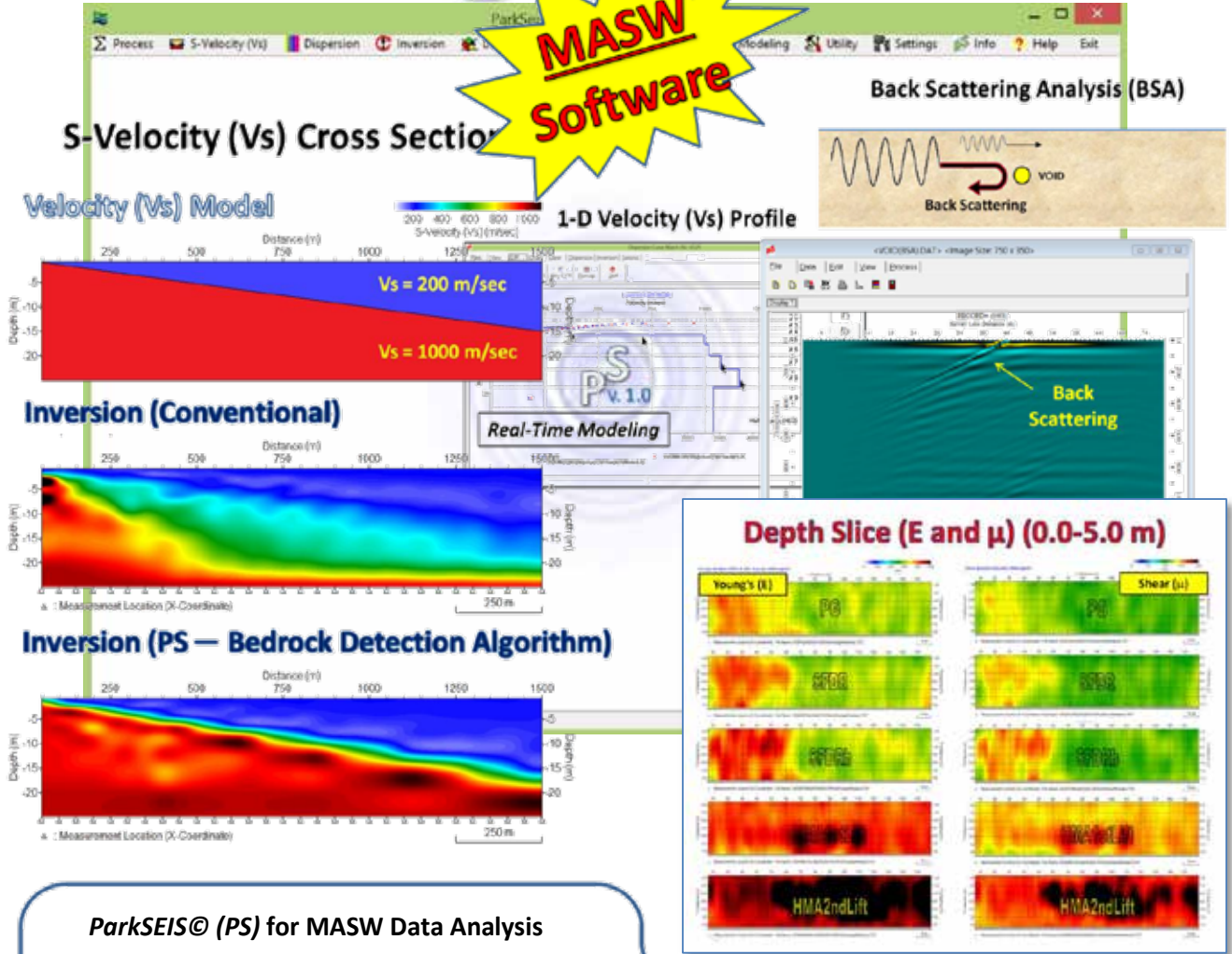


## **Recent Developments in the Radio Magnetotelluric Method**

**December 2015**

**Volume 20, Number 4**

**NEW!**  
**ParkSEIS®**  
 parkseismic.com  
**PS**  
 Comprehensive Tool For  
 Multichannel Analysis of Surface Waves  
 (MASW)



**ParkSEIS® (PS) for MASW Data Analysis**

ParkSEIS® (PS) presents the most up-to-date algorithms in the development of MASW method to ensure the most accurate analysis results. It provides the most comprehensive tools to process data acquired through active, passive, and active/passive combined MASW surveys for

- shear-wave velocity ( $V_s$ ) profiles (1-D, 2-D, and depth slice)
- back scattering analysis (BSA) for anomaly detection (voids, tunnels, boulders, weak zones, etc.)
- common-offset sections for quick evaluation of subsurface conditions
- modeling MASW seismic records and dispersion curves

ParkSEIS® (PS) has been rigorously tested by processing data sets from hundreds of different sites under Windows XP, Vista, 7, and 8 operating systems with a minimum 1GB memory. It is available for purchase and lease. Visit [www.parkseismic.com](http://www.parkseismic.com) for more information or contact [parkseis@parkseismic.com](mailto:parkseis@parkseismic.com).

ParkSeismic LLC, Tel: 347-860-1223, [contact@parkseismic.com](mailto:contact@parkseismic.com)



# Contents

ISSN 1943-6505

This issue of *FastTIMES* is focused on radio magnetotelluric geophysical methods. The latest information on SAGEEP 2016 is also provided.

<a href="#">Calendar</a>	4
<a href="#">Presidents Message</a>	5
<a href="#">Open Letter to EEGS</a>	6
<a href="#">FastTIMES Editorial Team</a>	11
<a href="#">The JEEG Page</a>	13
<a href="#">Success with Geophysics</a>	17

<a href="#">Industry News</a>	36
<a href="#">Coming Events and Announcements</a>	40
<a href="#">EEGS Membership Application</a>	49
<a href="#">EEGS Corporate Members</a>	56
<a href="#">EEGS Store</a>	57

## Advertisers

<a href="#">Advanced Geosciences Inc.</a>	39
<a href="#">Exploration Instruments</a>	9
<a href="#">Geometrics(GeodeEM3D)</a>	3
<a href="#">Geometrics (OhmMapper)</a>	3
<a href="#">Geonics</a>	34
<a href="#">Geostuff</a>	39
<a href="#">Interpex</a>	48
<a href="#">Mount Sopris</a>	35
<a href="#">Park Seismic</a>	ii
<a href="#">R.T. Clark</a>	16
<a href="#">R.T. Clark (PEG)</a>	39
<a href="#">SEG (Eng. Seis.)</a>	16
<a href="#">SurfSeis</a>	12
<a href="#">Zonge</a>	48



Featured  
Article

## RECENT DEVELOPMENTS IN THE RADIO MAGNETOTELLURIC METHOD **17**

# FastTIMES

FastTIMES (ISSN 1943-6505) is published by the Environmental and Engineering Geophysical Society (EEGS). It is available electronically (as a pdf document) from the EEGS website ([www.eegs.org](http://www.eegs.org)).

## ABOUT EEGS

The Environmental and Engineering Geophysical Society (EEGS) is an applied scientific organization founded in 1992. Our mission:

*"To promote the science of geophysics especially as it is applied to environmental and engineering problems; to foster common scientific interests of geophysicists and their colleagues in other related sciences and engineering; to maintain a high professional standing among its members; and to promote fellowship and cooperation among persons interested in the science."*

We strive to accomplish our mission in many ways, including (1) holding the annual Symposium on the Application of Geophysics to Engineering and Environmental Problems (SAGEEP); (2) publishing the Journal of Environmental & Engineering Geophysics (JEEG), a peer-reviewed journal devoted to near-surface geophysics; (3) publishing *FastTIMES*, a magazine for the near-surface community, and (4) maintaining relationships with other professional societies relevant to near-surface geophysics.

## JOINING EEGS

EEGS welcomes membership applications from individuals (including students) and businesses. Annual dues are \$90 for an individual membership, \$50 for introductory membership, \$50 for a retired member, \$50 developing world membership, complimentary corporate sponsored student membership - if available, and \$300 to \$4000 for various levels of corporate membership. All membership categories include free online access to JEEG. The membership

application is available at the back of this issue, or online at [www.eegs.org](http://www.eegs.org).

## BOARD OF DIRECTORS

President

Lee Slater, Newark, NJ  
[lslater@rutgers.edu](mailto:lslater@rutgers.edu)

President, Elect

Bethany Burton, Denver, CO.  
[blburton@usgs.gov](mailto:blburton@usgs.gov)

Vice President, SAGEEP

Michael Powers, Denver, CO  
[mhpowers@usgs.gov](mailto:mhpowers@usgs.gov)

Vice President Elect, SAGEEP

Charles Stoyer, Golden, CO  
[charles@interpex.com](mailto:charles@interpex.com)

Vice President, Committees

Jacob Sheehan, Wheat Ridge, CO  
[jrsheehan@olsonengineering.com](mailto:jrsheehan@olsonengineering.com)

Vice President Elect, Committees

Mark Saunders, Buffalo, NY  
[Mark.Saunders@applurtd.com](mailto:Mark.Saunders@applurtd.com)

Past President

Moe Momayez, Tucson, AZ  
[moe.momayez@arizona.edu](mailto:moe.momayez@arizona.edu)

## AT-LARGE BOARD MEMBERS

Bradley Carr, Laramie, WY  
[bcarr1@uwyo.edu](mailto:bcarr1@uwyo.edu)

Bart Hoekstra, San Jose, CA  
[Bart@geometrics.com](mailto:Bart@geometrics.com)

Rick Hoover, Grantville, PA

[Rick.Hoover@quality-geophysics.com](mailto:Rick.Hoover@quality-geophysics.com)

John Jansen, West Bend, WI

[John.Jansen@lbgmn.com](mailto:John.Jansen@lbgmn.com)

Carole Johnson, Storrs, CT

[johnson.cdj@gmail.com](mailto:johnson.cdj@gmail.com)

Laura Sherrod, Kutztown, PA

[sherrod@kutztown.edu](mailto:sherrod@kutztown.edu)

## HEAD OFFICE

1720 South Bellaire, Suite 110  
Denver, Colorado 80222-4303;  
PH 303.531.751, FX 303.820.3844  
[staff@eegs.org](mailto:staff@eegs.org)

Executive Director

Kathie A. Barstnar  
[staff@eegs.org](mailto:staff@eegs.org)

Managing Director  
Jackie Jacoby, Denver, CO  
[staff@eegs.org](mailto:staff@eegs.org)

## CONTRIBUTORS

International Board Liaison

Micki Allen, Markham, ON, Canada  
[mickiallen@marac.com](mailto:mickiallen@marac.com)

General Chair, SAGEEP 2016

John Stowell, Denver, CO  
[john.stowell@mountsopris.com](mailto:john.stowell@mountsopris.com)

Technical Chair, SAGEEP 2016

Charles Stoyer, Golden, CO  
[charles@interpex.com](mailto:charles@interpex.com)

Editor, JEEG

Janet Simms, Vickburg, MS  
[janet.e.simms@erdc.usace.army.mil](mailto:janet.e.simms@erdc.usace.army.mil)

## SUBMISSIONS

To submit information for inclusion in *FastTIMES*, contact a member of the editorial team:

Editor in Chief

Barry Allred, Columbus, OH  
[Barry.Allred@ars.usda.gov](mailto:Barry.Allred@ars.usda.gov)  
614.292.4459

Associate Editor's

Dan Bigman

[dbigman@bigmangeophysical.com](mailto:dbigman@bigmangeophysical.com)

Nedra Bonal

[nbonal@sandia.gov](mailto:nbonal@sandia.gov)

Nigel Cassidy

[n.i.cassidy@keele.ac.uk](mailto:n.i.cassidy@keele.ac.uk)

Katherine Grote

[grotekr@mst.edu](mailto:grotekr@mst.edu)

Ron Kaufmann

[ron@spotlighttaeo.com](mailto:ron@spotlighttaeo.com)

Moe Monayez

[moe.momayez@arizona.edu](mailto:moe.momayez@arizona.edu)

To advertise in *FastTIMES*, contact:

Jackie Jacoby  
[staff@eegs.org](mailto:staff@eegs.org)  
303.531.7517

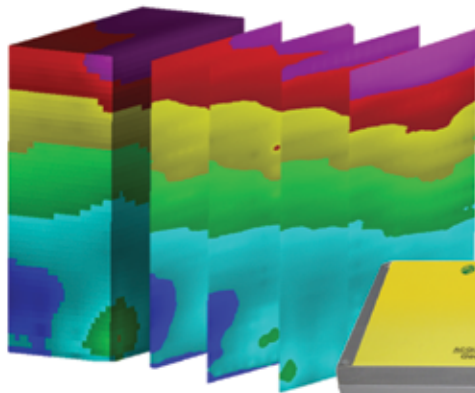
*FastTIMES* is published electronically four times a year. Please send articles to any member of the editorial team by Feb. 15, 2016. Advertisements are due to Jackie Jacoby by Feb. 15, 2016.

Unless otherwise noted, all material copyright 2016, Environmental and Engineering Geophysical Society. All rights reserved.

# Geode EM3D

*Mining Exploration Just Got Better!*

Full Tensor 2-D and 3-D Exploration CSAMT



- ➊ **More detailed information of your prospect**  
--Distributed network of up to 240 electric and magnetic sensors
- ➋ **Save time and money**  
--Over 150 simultaneous CSAMT soundings with a single transmitter acquisition run
- ➌ **More precise site characterization** --Highest resolution EM resistivity mapping
- ➍ **Reliable Ethernet communications**--no GPS dropouts, no lost satellites, no line-of-sight communication failures



**GEOMETRICS**  
Innovation • Experience • Results

FOR MORE INFORMATION:  
2190 Fortune Drive  
San Jose, CA 95131 U.S.A.

P: (408) 954-0522  
F: (408) 954-0902  
E: sales@geometrics.com

[www.geometrics.com](http://www.geometrics.com)

## OhmMapper: Capacitively-Coupled Resistivity System

- ⇒ No need for direct contact -- Measurements can be done over any surface (asphalt, pavement, ice, frozen ground, bedrock, etc.)
- ⇒ High quality, finely sampled near surface data -- even in areas with complex geology.
- ⇒ Simple coaxial-cable array can be pulled along the ground either by one person or a small vehicle (e.g. ATV)
- ⇒ Easy to use
- ⇒ No cumbersome galvanic electrodes
- ⇒ Extremely fast and continuous data collection



### EXCELLENT FOR:

- ❖ *Levee Studies*
- ❖ *Void & Cavity Detection*
- ❖ *Groundwater Exploration*
- ❖ *Mineral Exploration*
- ❖ *Archaeological Studies*
- ❖ *Agricultural Soil Resistivity Mapping*



**GEOMETRICS**  
Innovation • Experience • Results



P: (408) 954-0522 • F: (408) 954-0902 • E: sales@geometrics.com • 2190 Fortune Drive • San Jose, CA 95131 U.S.A. [www.geometrics.com](http://www.geometrics.com)

# CALENDAR

## 2016

- March 3 22nd Annual 3D Seismic Symposium  
Denver, Colorado, USA  
<http://www.rmag.org/3d-seismic-symposium>  
(Note: See page 46 for additional information.)
- March 3 - 4 SurfSeis - Multichannel Analysis of Surface Waves (MASW)  
Workshop  
Lawrence, Kansas, USA  
<http://www.kgs.ku.edu/software/surfseis/workshops.html>
- March 6 - 7 2nd Society of Exploration Geophysicists and Dahrhan  
Geoscience Society Workshop on Near Surface  
Modeling and Imaging  
Manama, Bahrain  
<http://www.seg.org/events/upcoming-seg-meetings/2016/ns-modelling-imaging-2016>
- March 20 - 24 Symposium on the Application of Geophysics to Engineering  
and Environmental Problems (SAGEEP)  
Denver, Colorado, USA  
<http://www.eegs.org/sageep-2016>  
(Note: See page 40 for additional information.)
- April 17 - 22 European Geosciences Union General Assembly 2016  
Vienna, Austria  
<http://egu2016.eu/home.html>
- May 9 - 13 Geophysics and Remote Sensing for Archaeology  
Pompeii, Italy  
[http://old.ibam.cnr.it/ARCHEO\\_School\\_finale.pdf](http://old.ibam.cnr.it/ARCHEO_School_finale.pdf)
- June 6 - 8 4th International Workshop on Induced Polarization  
Aarhus, Denmark  
<http://hgg.au.dk/ip2016/>
- August 21 - 24 Australian Society of Exploration Geophysicists 25th  
International Geophysical Conference and Exhibition  
Adelaide, Australia  
<http://www.conference.aseg.org.au/index.html>
- November 4 Rocky Mountain Geo-Conference  
Lakewood, Colorado, USA  
<http://www.aegrms.org/2016Geoconf.pdf>  
(Note: See page 45 for additional information.)

Please send event listings, corrections or omitted events  
to any member of the *FastTIMES* editorial team.

# PRESIDENT'S MESSAGE



**Lee Slater, President**  
([lslater@rutgers.edu](mailto:lslater@rutgers.edu))

## **Playing a Part**

EEGS is an organization that exists because of the hard work and remarkable volunteerism of the near surface geophysical community. In his letter that follows, EEGS member Ron Bell reminds us of the 'grass roots activism' that led to the formation of EEGS and the selfless efforts of so many members of our community to commit time and energy to the cause. Janet Simms, our JEEG Editor for the last eight years is an outstanding example of this work and volunteerism. Her tireless work at the helm of the journal has seen it through some challenging times during which, competing journals have been launched or have strengthened their focus on near surface geophysics contributions. The SAGEEP 2015 local organizers Jeff Paine, Brad Carr, Doug Layman and Dennis Mills performed wonders for the society in their endeavors to make sure that EEGS could once again achieve its full potential in convening a dedicated near surface geophysics meeting. As I write this message, John Stowell and Charles Stoyer are in the thick of SAGEEP 2016 preparations, requiring continuous demands on their time and energy. As a result of their contributions, I am looking forward to yet another successful SAGEEP meeting in Denver this March.

As you contemplate what you want to count as your achievements when you look back on 2016, I encourage you to make this the year in which you play your part in defining the future of our society. Janet Simms will be stepping down from her role as Editor of JEEG, and the journal will be looking for an inspirational new leader to volunteer to step up to define the next chapter of the history of the journal. This editor will need the support of a new team of dynamic, motivated Associate Editors to help strengthen the journal. SAGEEP 2017 will soon be upon us and the society will again be looking for the next group of volunteers to serve on the critical organizing committees and to dedicate significant time and energy to the cause.

Although a smaller organization relying on volunteerism is more vulnerable than a larger one, I am confident that EEGS will thrive this year. I am inspired by the fact that, in 2015, we saw five members of the society step up to serve as Associate Editors of FastTIMES and help Barry Allred continue his fine work producing this critical publication of the society. Furthermore, Ron Bell's letter describes a great example of activism in support of the organization by a member that cares passionately about its survival. With such efforts being made by members of the organization, it can only thrive. I therefore encourage you to consider making 2016 the year that you play a part in supporting EEGS. I challenge you to contact a [member of the EEGS Board of Directors](#) to find out how you can become engaged in supporting the society.

**Lee Slater, EEGS President**





# FOUNDATION NEWS



## ***EEGS Foundation makes great strides in its first years.***

Since the launch of the EEGS Foundation, there are numerous accomplishments for which we can all be proud: Establishing and organizing a structure that serves the needs of EEGS; underwriting the legal process, achieving tax-exempt status; and soliciting and receiving support for SAGEEP. In addition, the Foundation helped underwrite the SAGEEP conference held this spring in Keystone.

These are only a few of the tangible results your donations to the Foundation have enabled. We would therefore like to recognize and gratefully thank the following individuals and companies for their generous contributions:

Allen, Micki	Lecomte, Isabelle
Arumugam, Devendran	Long, Leland
Astin, Timothy	Lucius, Jeff
Baker, Gregory	Luke, Barbara
Barkhouse, William	MacInnes, Scott
Barrow, Bruce	Malkov, Mikhail
Billingsley, Patricia	Markiewicz, Richard
Blackey, Mark	Mills, Dennis
Brown, Bill	Momayez, Moe
Butler, Dwain	Nazarian, Soheil
Butler, Karl	Nicholl, John
Campbell, Kerry	Nyquist, Jonathan
Clark, John	Paine, Jeffrey
Doll, William	Pullan, Susan
Dunbar, John	Rix, Glenn
Dunscumb, Mark	Simms, Janet
Greenhouse, John	Skokan, Catherine
Harry, Dennis	Smith, Bruce
Holt, Jennifer	Soloyanis, Susan
Ivanov, Julian	Stowell, John
Jacobs, Rhonda	Strack, Kurt
Kerry Campbell	Thompson, Michael
Kimball, Mindy	Tsoflias, George
Kruse, Sarah	Van Hollebeke, Philip
LaBrecque, Douglas	Yamanaka, Hiroaki

Adaptive Technical Solutions LLC  
Corona Resources  
Exploration Instruments LLC  
Mt. Sopris Instruments

***“Guiding Technologies Today -Preparing for a World of Needs Tomorrow”***



# NOTES FROM EEGS

## Renew your EEGS Membership for 2016

Be sure to renew your EEGS membership for 2016! In addition to the more tangible member benefits (including the option of receiving a print or electronic subscription to JEEG, *FastTIMES* delivered to your email box quarterly, discounts on EEGS publications and SAGEEP registration, and benefits from associated societies), your dues help support EEGS's major initiatives such as producing our annual meeting (SAGEEP), publishing JEEG, making our publications available electronically, expanding the awareness of near-surface geophysics outside our discipline, and enhancing our web site to enable desired capabilities such as membership services, publication ordering, and search and delivery of SAGEEP papers. You will also have the opportunity to donate to the EEGS Foundation during the renewal process. Members can renew by mail, fax, or online at [www.eegs.org](http://www.eegs.org).

## Sponsorship Opportunities

There are always sponsorship opportunities available for government agencies, corporations, and individuals who wish to help support EEGS's activities. Specific opportunities include development and maintenance of an online system for accessing SAGEEP papers from the EEGS web site and support for our next SAGEEP. Make this the year your company gets involved! Contact Lee Slater ([lslater@rutgers.edu](mailto:lslater@rutgers.edu)) for more information.

# From the *FastTIMES* Editorial Team

*FastTIMES* is distributed as an electronic document (pdf) to all EEGS members, sent by web link to several related professional societies, and is available to all for downloading from the EEGS *FastTIMES* web site (<http://www.eegs.org/fasttimes>). Past issues of *FastTIMES* continually rank among the top downloads from the EEGS web site. Your articles, advertisements, and announcements receive a wide audience, both within and outside the geophysics community.

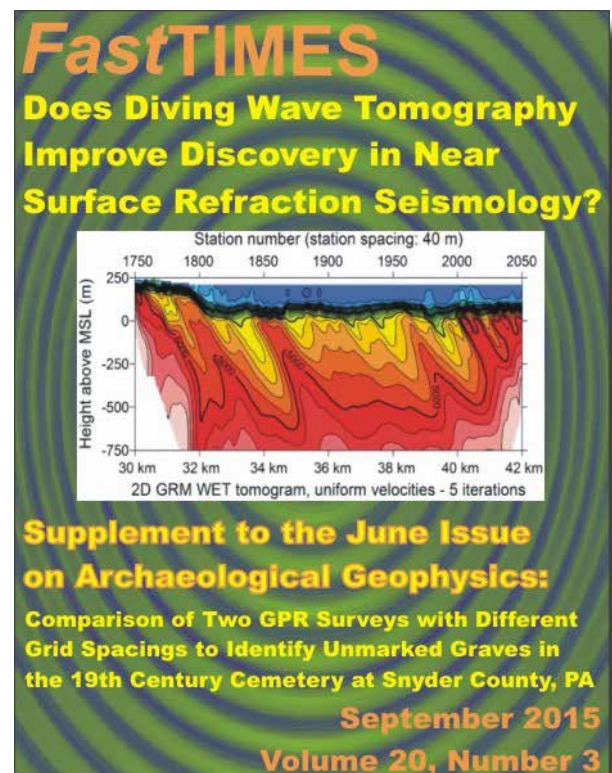
To keep the content of *FastTIMES* fresh, the editorial team strongly encourages submissions from researchers, instrument makers, software designers, practitioners, researchers, and consumers of geophysics—in short, everyone with an interest in near-surface geophysics, whether you are an EEGS member or not. We welcome short research articles or descriptions of geophysical successes and challenges, summaries of recent conferences, notices of upcoming events, descriptions of new hardware or software developments, professional opportunities, problems needing solutions, and advertisements for hardware, software, or staff positions.

The *FastTIMES* presence on the EEGS web site has been redesigned. At <http://www.eegs.org/fasttimes> you'll now find calls for articles, author guidelines, current and past issues, and advertising information.

**Special thanks are extended to Moe Momayez for his leadership in developing this issue of *FastTIMES* with its main topic focused on radio magnetotelluric geophysical methods.**

## Submissions

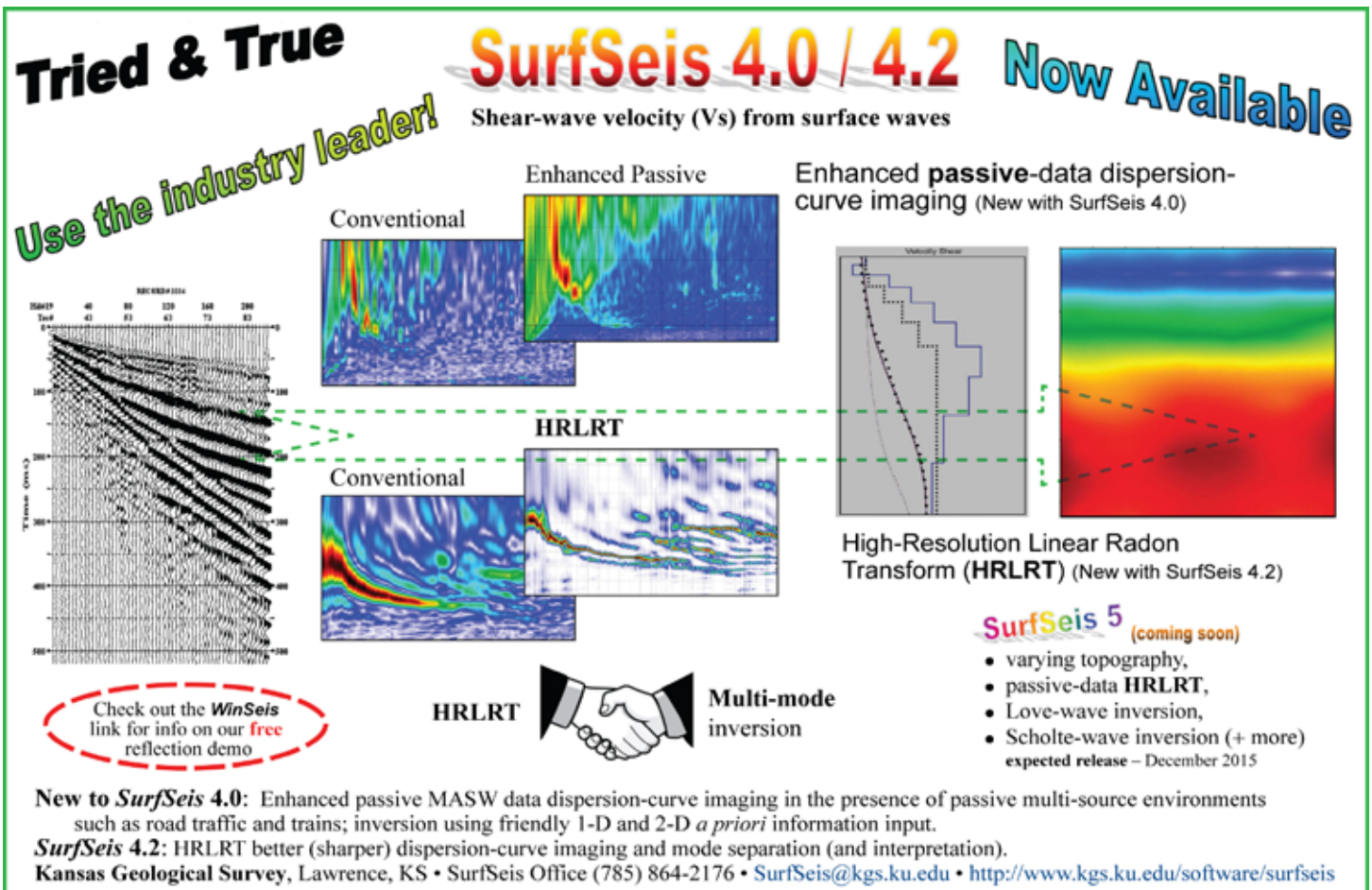
The *FastTIMES* editorial team welcomes contributions of any subject touching upon geophysics. *FastTIMES* also accepts photographs and brief non-commercial descriptions of new instruments with possible environmental or engineering applications, news from geophysical or earth-science societies, conference notices, and brief reports from recent conferences. Please submit your items to a member of the *FastTIMES* editorial team by Feb. 15, 2016 to ensure inclusion in the next issue. We look forward to seeing your work in our pages. Note: *FastTIMES* continues to look for Guest Editors who are interested in organizing a *FastTIMES* issue around a special topic within the Guest Editor's area of expertise. For more information, please contact Barry Allred ( [Barry.Allred@ars.usda.gov](mailto:Barry.Allred@ars.usda.gov) ), if you would like to serve as a *FastTIMES* Guest Editor.



# Message from the *FastTIMES* Editor-in-Chief

With our five new associate editors, 2016 promises to be a very exciting year for *FastTIMES*. Each 2016 issue will be focused on a special topic that we hope will be of great interest to our readers. The topic for the March 2016 *FastTIMES* will be the use of unmanned aerial vehicles (UAVs) in geology. Those interested in the contributing a UAV article to the March issue should contact Ron Bell (Aerobotic Geophysical Systems, LLC, [rbell@igsdenver.com](mailto:rbell@igsdenver.com)). The June 2016 *FastTIMES* will focus on forensic geophysics, and if you are interested in submitting a manuscript on this topic, please get in touch with Dan Bigman ([dbigman@bigmangeophysical.com](mailto:dbigman@bigmangeophysical.com)). The September 2016 *FastTIMES* will have articles devoted to karst geophysics, and if you wish to contribute a karst geophysics article, contact Ron Kauffman ([ron@spotlightgeo.com](mailto:ron@spotlightgeo.com)). We welcome suggestions from our readers concerning potential topics for future issues of *FastTIMES*. Again, we now encourage our readers to submit letters to the editor regarding comments on articles published in *FastTIMES*. Letters to the editor responding to articles in past issues should be sent to Barry Allred ([Barry.Allred@ars.usda.gov](mailto:Barry.Allred@ars.usda.gov)).

**Barry Allred, *FastTIMES* Editor-in-Chief, [Barry.Allred@ars.usda.gov](mailto:Barry.Allred@ars.usda.gov)**



**Tried & True**  
*Use the industry leader!*

## SurfSeis 4.0 / 4.2 Now Available

Shear-wave velocity ( $V_s$ ) from surface waves

Enhanced Passive  
Conventional  
HRLRT

Enhanced passive-data dispersion-curve imaging (New with SurfSeis 4.0)


High-Resolution Linear Radon Transform (HRLRT) (New with SurfSeis 4.2)

**SurfSeis 5 (coming soon)**

- varying topography,
- passive-data HRLRT,
- Love-wave inversion,
- Scholte-wave inversion (+ more)

expected release – December 2015

Check out the **WinSeis** link for info on our **free** reflection demo

HRLRT  Multi-mode inversion

**New to SurfSeis 4.0:** Enhanced passive MASW data dispersion-curve imaging in the presence of passive multi-source environments such as road traffic and trains; inversion using friendly 1-D and 2-D *a priori* information input.  
**SurfSeis 4.2:** HRLRT better (sharper) dispersion-curve imaging and mode separation (and interpretation).  
Kansas Geological Survey, Lawrence, KS • SurfSeis Office (785) 864-2176 • [SurfSeis@kgs.ku.edu](mailto:SurfSeis@kgs.ku.edu) • <http://www.kgs.ku.edu/software/surfseis>

# JEEG NEWS AND INFO

The Journal of Environmental & Engineering Geophysics (JEEG), published four times each year, is the EEGS peer-reviewed and Science Citation Index (SCI®)-listed journal dedicated to near-surface geophysics. It is available in print by subscription, and is one of a select group of journals available through GeoScienceWorld ([www.geoscienceworld.org](http://www.geoscienceworld.org)). JEEG is one of the major benefits of an EEGS membership. Information regarding preparing and submitting JEEG articles is available at <http://jeeg.allentrack.net>.



## December 2015 - Volume 20 - Issue 4

### Comparison of MASW and MSOR for Surface Wave Testing of Pavements

*Shilin Lin and Jeremy C. Ashlock*

### Spatial Variation of Shear Wave Velocity of Waste Materials from Surface Wave Measurements

*William Greenwood, Dimitrios Zekkos, and Andhika Sahadewa*

### Geophysical Characterization of an Undrained Dyke Containing an Oil-Sands Tailings Pond, Alberta, Canada

*Aaron P. Booterbaugh, Laurence R. Bentley, and Carl A. Mendoza*

### Resistivity Arrays as an Early Warning System for Monitoring Runoff Holding Ponds

*Bryan Woodbury, Roger Eigenberg, and Trenton E. Franz*

## Editor's Note

Dr. Janet E. Simms  
JEEG Editor-in-Chief  
US Army Engineer R&D Ctr.  
3909 Halls Ferry Road  
Vicksburg, MS 39180-6199  
(601) 634-3493; 634-3453 fax  
[janet.e.simms@erdc.usace.army.mil](mailto:janet.e.simms@erdc.usace.army.mil)



The Journal of Environmental and Engineering Geophysics (JEEG) is the flagship publication of the Environmental and Engineering Geophysical Society (EEGS). All topics related to geophysics are viable candidates for publication in JEEG, although its primary emphasis is on the theory and application of geophysical techniques for environmental, engineering, and mining applications. There is no page limit, and no page charges for the first ten journal pages of an article. The review process is relatively quick; articles are often published within a year of submission. Articles published in JEEG are available electronically through GeoScienceWorld and the SEG's Digital Library in the EEGS Research Collection. Manuscripts can be submitted online at <http://www.eegs.org/jeeg>.



The Environmental and  
Engineering Geophysical Society

## CALL FOR PAPERS

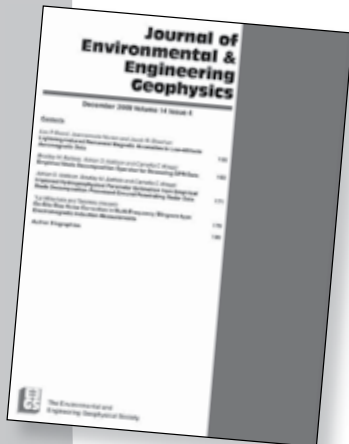
### Airborne Geophysics Special Issue of the Journal of Environmental and Engineering Geophysics

The Journal of Environmental and Engineering Geophysics (JEEG) announces a Call for Papers for a special issue on Airborne Geophysics. This issue is scheduled for publication in March 2017.

The special issue co-editors are Antonio Menghini, Aarhus Geophysics, Denmark and Les Beard, Zonge International, Arizona, USA. Sponsorship of this issue is still open.

**Suggested themes are:**

- New developments in equipment
- Novel airborne geophysical systems, including unmanned systems
- Data acquisition, modeling, and inversion
- Case histories, including:
  - hydrogeology, including soil salinity
  - engineering
  - ordnance detection
  - environment
  - mining
  - exploration



International contributions are encouraged. The special issue will accommodate six to eight papers, but all accepted papers will be considered for publication in other JEEG issues.

Papers may be submitted through the JEEG submission site, <http://jeeg.alltrack.net>. Indicate in the cover letter that the paper is for consideration in the Airborne Geophysics special issue.

**The deadline for submissions is February 28th, 2016.**

*Questions may be directed to:*

Special Issue Co-Editors—Antonio Menghini, [am@aarhusgeo.com](mailto:am@aarhusgeo.com)

Les Beard, [LPBeard@comcast.net](mailto:LPBeard@comcast.net)

JEEG Editor—Janet Simms, [Janet.E.Simms@usace.army.mil](mailto:Janet.E.Simms@usace.army.mil)

**[www.eegs.org](http://www.eegs.org)**

# **SUPPORT** EEGS **TODAY**

**JOIN OR RENEW  
SUBMIT AN ARTICLE  
GET INVOLVED!**

**START HERE.**





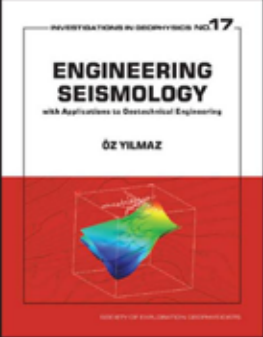
**The  
R.T. Clark  
Companies Inc.**

**Seismographs  
GPR  
Geophones  
Mags  
Cables  
Resistivity  
Loggers  
EM & More!!!**



**Web: [rtclark.com](http://rtclark.com) Email: [rtclark@rtclark.com](mailto:rtclark@rtclark.com)  
Tele: 405-751-9696 Fax: 405-751-6711  
P.O.Box 20957, Oklahoma City, Oklahoma 73157 USA**

**Engineering Seismology**  
with Applications to Geotechnical Engineering  
**ÖZ YILMAZ**

The theory and practice of near-surface seismology, including site characterization, landslide investigations, active fault investigations, seismic microzonation, geophysical investigations of historic buildings, and exploration of earth resources.



Catalog #120A  
Published 2015, 964 pages, Hardcover  
ISBN 978-1-56080-329-4  
SEG Members \$159, List \$199  
e-Book eISBN 978-1-56080-330-0  
SEG Members \$135, List \$169  
Order online at: [www.seg.org/bookmart](http://www.seg.org/bookmart)  
Learn more at: [www.seg.org/newbooks](http://www.seg.org/newbooks)



# SUCCESS WITH GEOPHYSICS

*FastTIMES* welcomes short articles on applications of geophysics to the near surface in many disciplines, including engineering and environmental problems, geology, hydrology, agriculture, archaeology, and astronomy. This issue of *FastTIMES* is focused on radio magnetotelluric geophysical methods. There is one article on radio magnetotelluric geophysics in this December *FastTIMES*, and a second article may be added to an updated issue the the near future. As always, readers are very much encouraged to submit letters to the editor for comments on articles published in *FastTIMES*.

## RECENT DEVELOPMENTS IN THE RADIO MAGNETOTELLURIC METHOD

**Wanjie Feng, Doctoral Candidate**  
**Department of Mining and Geological Engineering**  
**The University of Arizona**  
**Tucson, Arizona, USA**  
email: [wanjiefeng@email.arizona.edu](mailto:wanjiefeng@email.arizona.edu)

### Abstract

The radio magnetotelluric (RMT) method is a plane-wave frequency domain electromagnetic method using military and civilian radio transmitters as its sources and working in the frequency range of 1 kHz to 1 MHz. Due to its high-frequency, it is widely used to probe the near-surface region, such as contaminated vadose, buried waste, and archaeological sites, agricultural drainage, fracture zone, hydrogeology, and other near-surface targets. This paper reviews the development of RMT theory, data processing and interpretation, and instruments over the past three decades. The main points are summarized below.

RMT method uses the impedance and tipper parameters to express information about subsurface structures. The noise coexists with the electric and magnetic fields, which could cause errors in the computation of impedance and tipper. One new approach to mitigate the effect of noise is to account for the source information when processing and interpreting RMT data. The RMT transfer function which expresses the relationship between the electric and magnetic fields is not constant over a wide range of frequencies. A common approach to solve this problem is to use an extended version of the Weidelt's C expansion.

Instruments have played an essential role in the development of the RMT method. Since the 1980s, several RMT instruments such as the IPI-1000, RMT-F, EnviroMT, ADU-07e, and RMT-M have been developed. Most RMT instruments employ an induction coil as a magnetic sensor and grounded or non-grounded electrodes as an electric field sensor. Some of the non-grounded electrodes have been demonstrated to have a sensitivity equivalent to or better than grounded electrodes, such as, the En3c and eQubeTM. Whether ground or capacitive electrodes are used depends on the impedance of electrodes at a particular site. For a capacitively coupled electrode, the common assumption of an ideally conducting full-space or half-space breaks down at high frequencies greater than 100 kHz in a resistive medium.

**Keywords:** Radio Magnetotelluric (RMT) Method, Electric Field, Magnetic Field, Weidelt's C Function Expansion, Impedence Tensor, and Tipper Vector.

As a derivative of the magnetotelluric (MT) method, RMT has an identical set of governing equations. As a result, some of the well-developed data processing and interpretation methods could be utilized directly to analyze RMT data. However, occasionally, adjustments are made to the commonly used data processing techniques in order to deal with the high-frequency content of the signals more efficiently. Recent advances in the theory, instrumentation, data processing, and interpretation of RMT data has created new opportunities for a wide range of applications in the field of near-surface geophysics.

## Introduction

Ever since Cagniard (1953) first introduced the magnetotelluric method, MT and its derivatives have been utilized to image deep subsurface structures around the world. This method measures naturally-occurring and time-varying magnetic and electric fields in the Earth. Low-frequency ( $< 1$  Hz) signals are created by the interaction between solar winds and the Earth's magnetic field. As solar storms emit streams of ions, this energy disturbs the earth's magnetic field and causes low-frequency energy to penetrate the earth's surface. High-frequency signals are created by lightning activity around the world. The energy created by these electric storms travels around the Earth (in a waveguide between the earth's surface and the ionosphere). Typically, these signals are small in amplitude. However, where high-frequency MT measurements are desirable, the RMT method utilizes artificial sources (Goldstein and Strangway, 1975) such as commercial and military radio transmitters in the frequency range of 1 kHz to 1 MHz (Bastani et al., 2015) to probe the subsurface.

Based on the skin depth theory, RMT is a good candidate for near-surface investigations. The near-surface of the Earth (up to 100 m) is the region that supports man-made infrastructure, contains a large amount of drinking water, and is the interface between solid Earth and atmosphere for many bio-geo-chemical cycles that sustain life (Ismail, 2009). Having a thorough understanding of this region helps attracts more and more attention. RMT is a geophysical method that is highly reliable for this type of shallow subsurface applications.

Since 1980s, several RMT instruments have been developed. An analogue RMT system, the IPI-1000, working in frequency range of 10-1000 kHz was developed in Leningrad (now St. Petersburg) State University in the 1980s (Saraev et al., 1999). A scalar RMT system, RMT-R, operating in the frequency band 12-240 kHz has been developed at the University of Neuchatel, Switzerland. This system was used to study a porous aquifer in the Cornol area, Switzerland (Turberg et al, 1994). Hollier-Larousse et al. have also developed a RMT system (10 kHz - 1 MHz) in 1994, that measures apparent resistivities (no phase information) for selected frequencies (Tezkan, 1999). The Stratagem system of Geonics developed around 2000, allows tensor measurements, however it was designed for AMT. As a result, its frequency range is limited to 92 kHz (Stratagem, 2015). Bastani (2001) introduced a new instrument, the EnviroMT. The instrument conducts tensor measurements. A few publications have reported the capability of this instrument. A new four channel instrument RMT-F was developed in 2005 by the St. Petersburg State University, MicroKOR Ltd., and University of Cologne (Tezkan and Saraev, 2007; Tezkan, 2009a, 2009 b). It records a time series of the horizontal components of the electric and magnetic fields in a wide frequency band from 10 kHz to 1 MHz simultaneously. These new instruments have prompted a rapid development of RMT applications.

The above-mentioned instruments employ four channels: two for the horizontal magnetic fields and two for the horizontal electric fields. A few also measure the vertical magnetic field. All instruments depend on grounded electrodes to detect the electric fields. This limits the use of these instruments in some applications, such as ice, pavement, and permafrost areas, where it is challenging to provide strong coupling between the electrodes and the material. Another limitation of these instruments is speed. To collect data at high speed and spatial resolution, an alternative method is to use capacitive or non-contact electrodes. This technique has been used successfully in several capacitive resistivity sounding (Shima et al., 1996; Dashevsky et al., 2005; Neukum et al., 2010; Hibbs et al., 2011; Niu et al., 2014; Terraplus, 2015). Instruments using this technique are OhmMapper, eQubeTM, and CORIM. The first investigations with a mobile VLF-R instrument had been conducted in the Soviet Union in

1970s to determine the rock mass resistivity in vast areas for broadcasting purposes (Simakov et al., 2010). Simakov et al. (2010) developed a mobile RMT-M system based on the RMT-F single-point measurement instrument, and acquired data at speeds up to 5-7 km/h. Saraev et al (2012) developed and experimented with capacitive sensors for Audio Magnetotelluric (AMT) surveys using an ACF-4M instrument. Seven 600 Hz experiments indicated that capacitive electric sensors can perform AMT works both in summer and winter seasons with data quality comparable to grounded electrodes. Macnae and his colleagues have performed numerous studies using electric sensors (Macnae and McGowan, 1991; Macnae, 2010). In a recent breakthrough in non-contact electric field measurement at RMIT University, Macnae used charge amplifiers to conduct an investigation in the low-frequency range of 20Hz to 20kHz. Whether a ground coupled or capacitive electrodes is used depends on the contact impedance of the electrodes (Hordt et al., 2013).

RMT uses military and civilian radio stations as transmitters. It differs from MT technique in terms of its higher frequency range of measurement and the origin of the sources used, however, the governing equations for both methods are identical. Consequently, the existing computer code used in the interpretation of MT signals can be directly used to analyze RMT data (Newman et al., 2003; Candansayar and Tezkan, 2008; Bastani et al., 2012). In addition, considering the higher frequencies used in RMT studies, several new modeling and inversion schemes have been developed (Pedersen and Gharibi, 2000; Kalscheuer et al., 2008). In recent years, RMT has been successfully applied in to investigate vadose contaminated sites, buried waste sites, archaeology, agricultural drainage, groundwater, fracture zone, hydrogeology and other near-surface explorations (Turberg et al., 1994; Tezkan, 1999; Newman et al., 2003; Linde and Pedersen, 2004; Tezkan and Saraev, 2007; Bastani et al., 2012). In this paper, we present the basic theory of MT followed by advances in data processing and interpretation. We also discuss instruments of RMT, magnetic and electric field sensors, with a special emphasis on capacitively coupled electric sensors.

### Theory of RMT

The principle of RMT is demonstrated schematically in Figure 1. RMT, a derivative of the magnetotelluric method, uses radio transmitters as its source. Fundamentally, it is a plane-wave frequency domain method where two horizontal electric fields and three magnetic fields are measured on the earth surface. A sketch of an RMT station is shown in Figure 2. The relationship between the measured components in the frequency domain is represented by the complex impedance and tipper, which reflect the electrical properties of underground anomalies. For a tensor RMT measurement, the complex impedance is linear (in the narrow frequency band) and can be simply expressed in the frequency domain as (Bastani et al., 2012):

$$\mathbf{E}(f) = \mathbf{Z}(f)\mathbf{H}(f) \tag{1}$$

where

$$\mathbf{E}(f) = \begin{bmatrix} E_x(f) \\ E_y(f) \end{bmatrix} \text{ and } \mathbf{H}(f) = \begin{bmatrix} H_x(f) \\ H_y(f) \end{bmatrix}$$

where  $\mathbf{E}$  and  $\mathbf{H}$  are the Fourier transforms of the measured electric and magnetic fields, respectively; subscripts x, y, and z represent the N-S, E-W and vertical components, respectively;  $f$  is the transmitter frequency, and  $\mathbf{Z}$  is the complex impedance tensor. For each frequency,  $\mathbf{Z}$  is a  $2 \times 2$  complex matrix:

$$\mathbf{Z}(f) = \begin{bmatrix} Z_{xx}(f) & Z_{xy}(f) \\ Z_{yx}(f) & Z_{yy}(f) \end{bmatrix} \tag{2}$$

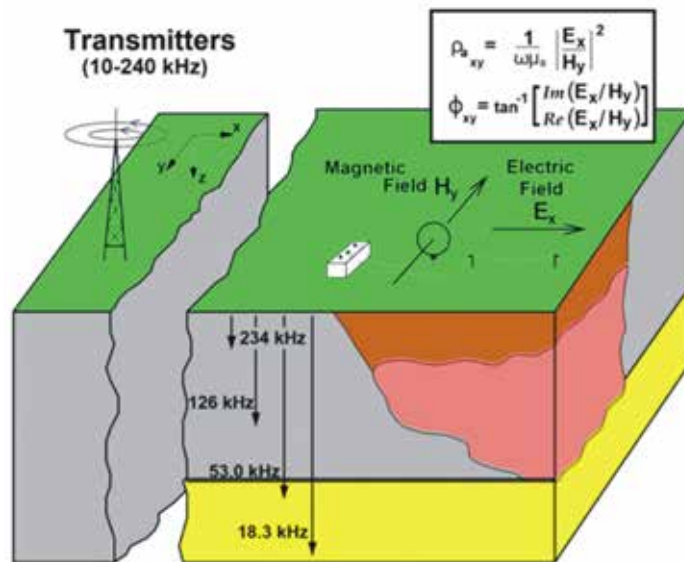
The tipper vector is another important parameter that carries information about the subsurface. It shows the relationships between the vertical magnetic field and the two horizontal magnetic fields. It is simply expressed as:

$$H_z(f) = \mathbf{T}(f) \begin{bmatrix} H_x(f) \\ H_y(f) \end{bmatrix}, \mathbf{T}(f) = [A(f) B(f)] \quad (3)$$

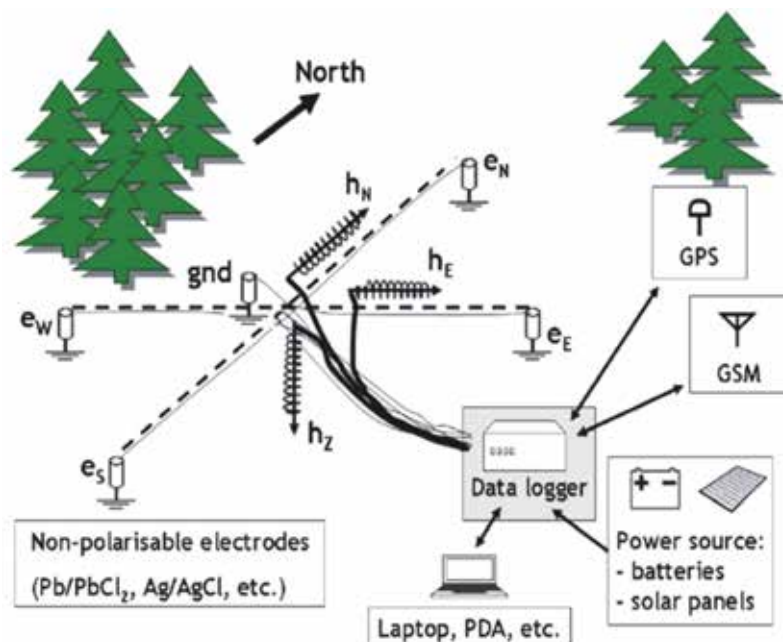
The impedance and tipper vectors are complex and frequency dependent. For a layered one dimensional (1D) earth, the anti-diagonal elements of the impedance tensor are zero,  $Z_{xy} = -Z_{yx} = 0$  and the apparent resistivity and phase of impedance can be calculated as:

$$\rho_a(f) = \frac{|\mathbf{Z}(f)|^2}{2\pi f \mu_0} \text{ and } \varphi(f) = \arg|\mathbf{Z}(f)| \quad (4)$$

where  $\mu_0$  is the magnetic permeability of the vacuum. In a two-dimensional (2D) earth model the main diagonal elements are zero and the apparent resistivity is direction-dependent and is defined in two perpendicular directions, namely  $xy$  and  $yx$  using Equation (4) with  $\mathbf{Z}$  equal to  $Z_{xy}$  and  $Z_{yx}$  (Bastani et al., 2013).



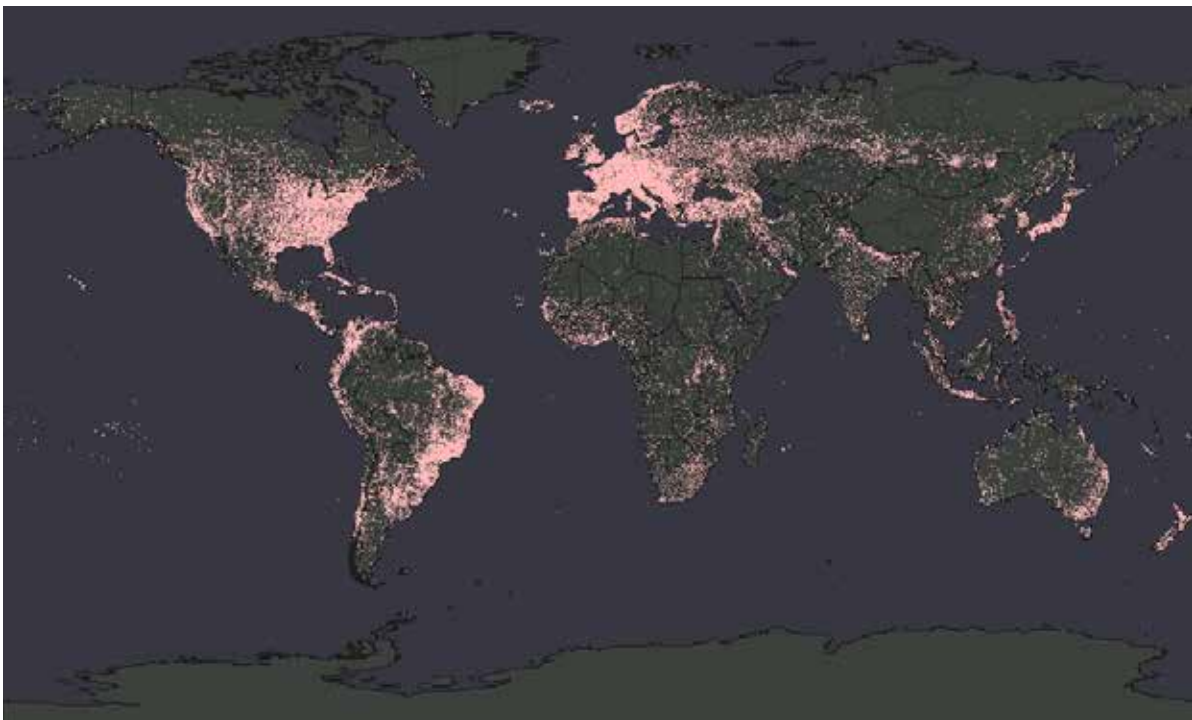
**Figure 1.** Schematic diagram for illustrating a RMT field setup over a hazardous waste site (Tezkan et al., 2001).



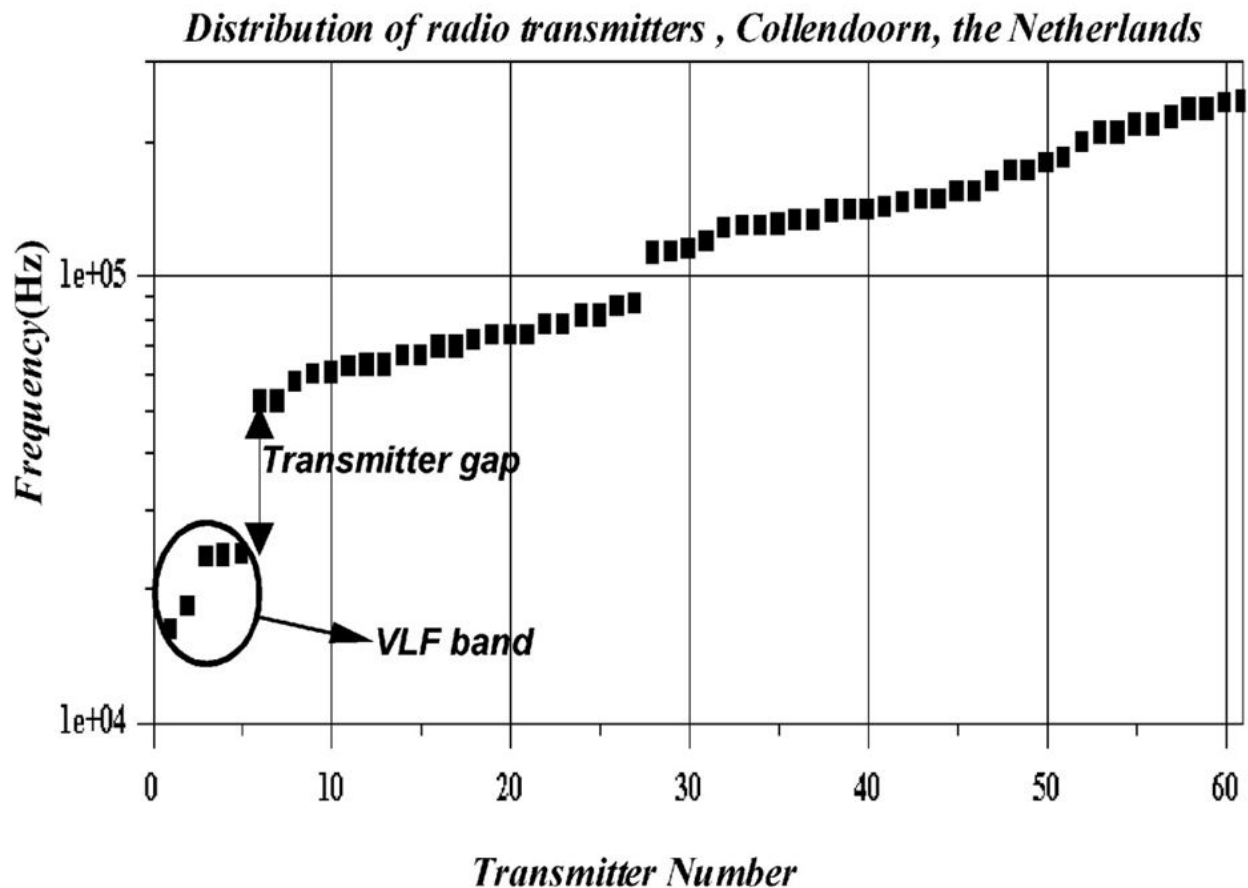
**Figure 2.** Sketch of a general RMT site (Smirnov et al, 2008).

Assuming a plane-wave excitation, for a fixed position over the earth surface at a given frequency, there exists a unique impedance and tipper representing the relationship between the magnetic fields and the electric fields. In practice, a number of steps are needed in order to estimate the impedance and tipper in Equations (2) and (3). The electromagnetic components measured at the earth's surface may be contaminated by noise from various sources. The basic assumption of a plane-wave source field may also be violated if the receiver is too close to a particular source, e.g., a VLF radio transmitter (Bastani and Pedersen, 2001). The classical way of calculating the impedance tensor and the tipper vector is to assume that the noise is concentrated in the electric field components (Pedersen, 1982). In this assumption, the impedance and tipper can be solved directly from residual power in the electric field and vertical magnetic field. However, a noise-free magnetic field is almost impossible to achieve at present time. The remote reference technique was introduced to remove the need to assume noise-free magnetic field (Gamble et al., 1979). However, the remote reference technique averages the data over long periods of time, and often produces results that are corrupted due to the significant presence of non-stationary noise (Hennessy, 2015). One new approach is accounting for the source information and using its physical properties when processing and interpreting RMT data. This scheme can also increase the signal-to-noise ratio (SNR) (Ritter et al., 1998; Hennessy, 2015, Hennessy and Macnae, 2015).

A fundamental assumption in standard MT impedance tensor and tipper vector calculation is that the transfer function is constant in a narrow frequency band. Typically, a bandwidth of half an octave is used. However, this assumption may distort the estimates for several reasons. In most cases, the distribution of radio transmitters deviates considerably from region to region worldwide as shown in Figure 3. Even with a large number of radio transmitters, the frequencies may not cover a large frequency range. Figure 4 is an example of the distribution of radio transmitter frequencies in the Netherlands during mid-November 1998. There is one transmitter gap in the octave from 20 to 40 kHz. Another complication is that even though the number of transmitters in a given half-octave band is high, their azimuths may deviate only slightly, which may cause the estimation of impedance and tipper to fail (Bastani and Pedersen, 2001). One solution is using an extended version of the Weidelt's C function expansion. The expansion coefficients are found from solving a mixed determined linear inverse problem by a truncated singular-value decomposition technique with a truncation level determined automatically from the data (Bastani and Pedersen, 2001).



**Figure 3.** A worldwide map of all FM radio transmitter sites.



**Figure 4.** An example of radio transmitter distribution in Collendoorn, the Netherlands (Bastani and Pedersen, 2001)

In the case of MT and AMT, electromagnetic fields of natural sources behave like plane-waves on the surface of the earth with a small amount of energy propagating vertically downward into earth (Vozoff, 1991). However, this is not valid for RMT because of the high-frequency of source signals. The plane-waves that are obliquely incident to the surface of the earth will not travel vertically in the earth. As a result, the impedance tensor and tipper vector become a function of incident angle or the horizontal wavenumber. Therefore, to accurately extract the impedance and tipper information, it is necessary to calculate the incident angle or the horizontal wavenumber (Song et al., 2002).

### **Data Processing and Interpretation**

Data processing and interpretation is a key part of any geophysical investigation. It is important for RMT to image the underground geological structures accurately. This objective is realized with modeling and inversion of RMT data. Depending on the complexity of the subsurface structures, the modeling and inversion could be performed in 1D, 2D or 3D. Often, it is necessary to process and interpret RMT data together with other geophysical methods, such as DC, AEM, or seismic, in order to obtain a more detailed picture.

As an extension of the VLF method and a derivative of the MT method, RMT can directly utilize many of the VLF and MT modeling and inversion schemes, because all three techniques share the same governing equations. The only difference is the range of frequencies used in each method. RMT uses military and civilian radio stations broadcasting in a frequency range between 10 kHz and 1 MHz as transmitters. The higher frequencies pose challenges in modeling and inversion of the data, for example, whether or not displacement currents should be neglected. However, with little modification, the same modeling and inversion techniques used in MT and AMT can be successfully applied in RMT studies.

## RECENT DEVELOPMENTS IN THE RADIO MAGNETOTELLURIC METHOD

There are many examples of RMT investigations that directly utilized well-developed modeling and inversion schemes. Newman et al. (2003) experimented with 3D inversion of scalar RMT data using non-linear conjugate gradients in a waste site. The inverse image clearly detects the buried waste and the lateral extent of the pit. However, the base of the pit is poorly resolved as it is dependent on the starting model. They also compared their results with a 2D inversion scheme. Their findings indicate that 2D MT interpretation can overestimate the pit's depth extent. Candansayar and Tezkan (2008) developed an algorithm for the 2D joint-inversion of RMT and direct-current resistivity (DC) data. They used a finite-difference technique to solve the Helmholtz and Poisson equations for RMT and DC method respectively. Specifically, the finite-difference forward solution and partial derivative matrix calculations for the MT data inversion were solved using the R2DMTINV algorithm. A regularized inversion with a smoothness-constrained stabilizer was employed to invert both data sets. The RMT method is not particularly sensitive when attempting to resolve near-surface resistivity blocks because it uses a limited range of frequencies. On the other hand, the DC method can resolve these near-surface blocks with relatively greater accuracy. The joint-inversion of synthetic data showed that the joint-inversion of RMT and DC gives more accurate results than any individual inversion of the data set. Subsequently, the 2D joint-inversion results from the field data indicated that the fault was located more accurately than the individual inversion of RMT and DC data. Commer and Newman (2008) presented new techniques for improving both the computational and imaging performance of the 3D electromagnetic inverse problem using non-linear conjugate gradient algorithm. Several schemes must be employed in modeling the mesh, defining model parameters, and grid spacing. Two different levels of parallelization were introduced into the computation. Source signature correction was used to alleviate the data distortions in both amplitude and phase. Bastani et al. (2012) applied a 2D joint-inversion program to RMT and electrical resistivity tomography (ERT) in their contaminated groundwater study in Italy. Also, they compared the 2D joint-inversion results with 3D individual inversion model. The 2D joint-inversion program, EMILIA, provided more details closer to the surface, and could resolve high resistivity structures more accurately. The 3D inversion code, WSINV3DMT, on the other hand, resolved conductive features with better resolution and modeled the depth to the top and the thickness of the water saturated zone more accurately. Egbert and Kelbert (2012) developed a general mathematical framework for Jacobian computation, which is a key component in all gradient-based inversion methods, and also provides the basis for the development of a modular system of computer codes for inversion of EM geophysical data. Though they focused the inversion problems of 2D and 3D MT, their schemes could also be utilized in other EM methods. Garbajal et al. (2012) used numerical methods to analyze the extent to which the inversion results of AMT and RMT groundwater monitoring data can be improved by (1) time-lapse difference inversion; (2) incorporation of statistical information about the expected model update; (3) using alternative model norms to quantify temporal changes; and (4) constraining model updates to predefined ranges. Their results confirm that the approximate  $l_1$ -norm solutions can resolve both sharp and smooth interfaces within the same model. Penalizing models updating with non-physical variations was shown to be successful not only in avoiding inversion artifacts, but also, in the case of the perturbed  $l_1$ -norm, to better determine the magnitudes of the time-lapse changes. Sudha et al. (2014) developed a common 1D weighted joint-inversion algorithm for helicopter-borne electromagnetic (HEM), transient electromagnetic (TEM) and radio magnetotelluric (RMT) data. This technique takes advantage of each method, thus providing the capability to resolve near-surface (RMT) and deeper electrical conductivity structures (TEM) in combination with valuable spatial information (HEM). Therefore, the joint-inversion of HEM, TEM, and RMT would yield quasi-2D and quasi-3D images of the electrical conductivity over a large depth interval by concatenating the 1D interpreted models. Bastani et al. (2015) directly used the 2D inversion program FEBOCC and the 3D code WSINV3DMT of MT with their RMT and CSRMT data. They tested these codes with field data from three different sites. The FEBOCC results are unstable and large rms errors were observed when processing field data from Iran – the error is mainly the result of too few radio transmitters in the study area. In the second study area located in Greece, they correlated FEBOCC inversion results with boreholes data in that area. The WSINV3DMT code produced a very good match with the borehole data in Sweden.

As mentioned previously, the high-frequency content of source signals used in RMT investigations requires that some modifications be made to the data processing and interpretations

techniques. Pedersen and Gharibi (2000) proposed one automatic layered inversion of plane-wave electromagnetic data that was carried out by modifying the standard least-squares inversion schemes. The modifications include a logarithmic reparameterization of the unknown model parameters, whereby all layer parameters are forced to remain within given bounds. The most important adjustment is to split the data into several sub-bands, starting from the highest frequencies. This new inversion procedure has shown that there is a very strong coupling between the resolution power of plane-wave data and their random errors. Pedersen and Engels (2005) built an inverse model using 2D models containing both 2D and 3D elements believed to be representative of shallow conductors in a crystalline basement overlain by a thin sedimentary cover. This new scheme is based on the determinant of the MT impedance tensor. Compared with traditional approaches, the new technique could remove much of the bias and improve the data fit. Also, the determinant of the impedance tensor is independent of the chosen strike direction, and once the a-priori model is set, the best-fit model is found to be practically independent of the starting model. Kalscheuer et al. (2008) discussed the 2D forward and inverse problems accounting for displacement currents. A 2D forward and inverse scheme was developed based on the REBOCC MT inversion program that can operate both with the quasi-static approximation and displacement currents. At high frequencies, and in highly resistive subsurface models (greater than 3000 Ohm-m), the apparent resistivities and phases of the TM and TE modes are significantly smaller than in the quasi-static approximation. When traversing a profile in 2D subsurface models, sign reversals in the real part of the vertical magnetic transfer function are often more pronounced than in the quasi-static approximation. In both cases, the responses computed including displacement currents are larger than typical measurement errors. The 2D inversion of synthetic data computed including displacement currents shows that serious misinterpretations in the form of artifacts in the inverse models can be introduced if displacement currents are neglected during the inversion process.

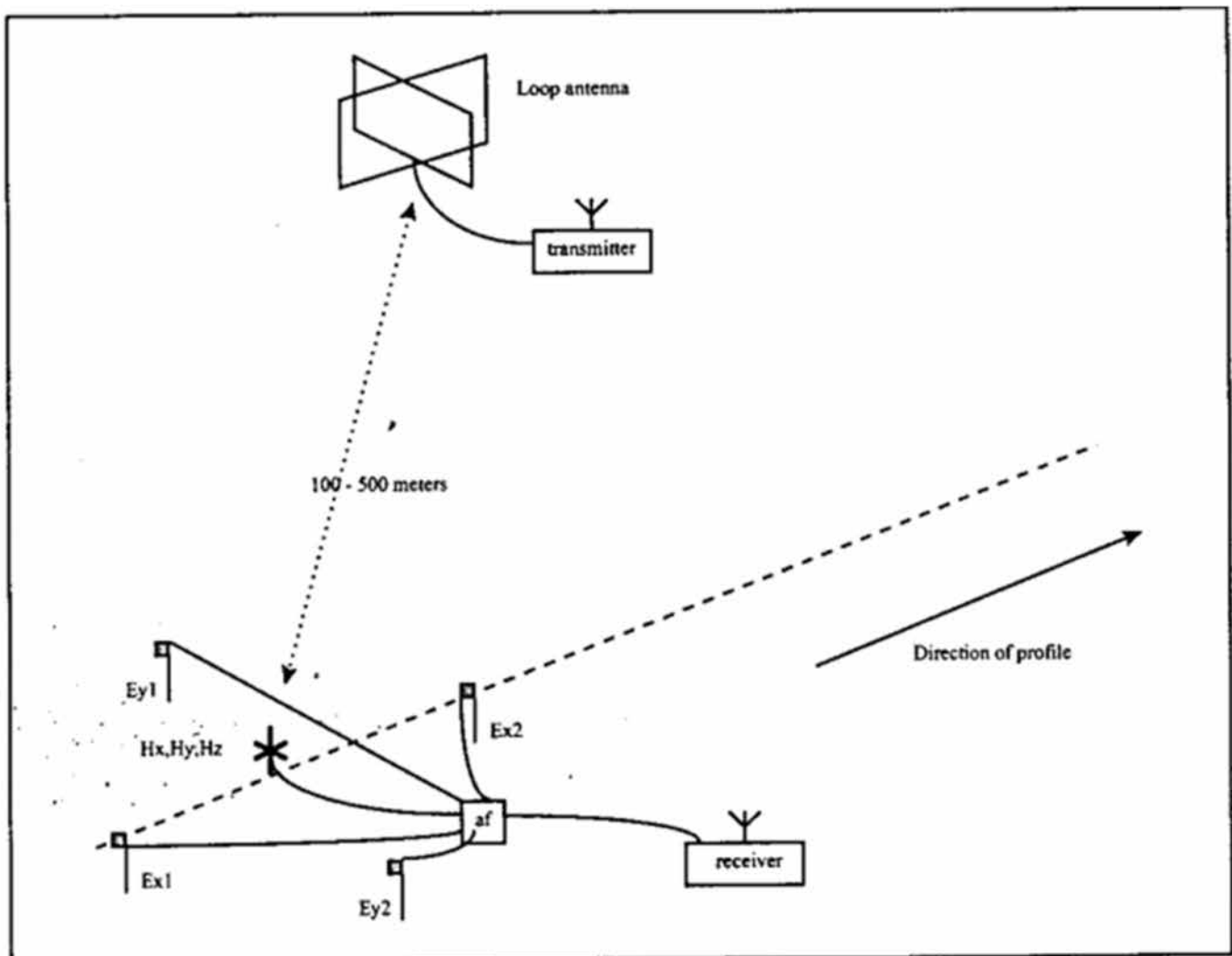
It is apparent that using well-developed data processing and interpretation techniques will reduce considerable cost and ensure that the results are reliable. However, algorithms that consider the character of RMT data and utilize existing inversion techniques produce more convincing results. For most of electromagnetic geophysical methods, the 3D modeling and inversion are in their infancy, while the 2D data processing and interpretation techniques still significantly reduce computing time, especially when modeling heterogeneous geologic media. However, these excellent studies on RMT data processing and interpretation advance RMT investigation and applications.

## RMT Instruments

The first RMT instrument was developed from a prototype built at the University of Neuchatel's Hydrogeological Institute in Switzerland (Muller, 1983). The horizontal component of the magnetic field is measured with a coil (0.4 m diameter), and the horizontal component of the electric field is measured with two grounded electrodes 5 m apart. The frequency range of this instrument is limited to 10-300 kHz. The instrument is lightweight and easy to use. About two minutes are necessary to measure apparent resistivities and phase values for four frequencies at every location. An analogue RMT system IPI-1000 working in frequency range of 10-1000 kHz was developed at Leningrad (now St. Petersburg) State University in the 1980s. This system makes use of magnetic and grounded electrical antennas. Besides detecting high frequencies, this system also collects data at 50 Hz (Saraev et al., 1999). Hollier-Larousse et al. developed an RMT system (10 kHz - 1 MHz) in 1994, however, only apparent resistivities (no phase information) for selected frequencies are measured (Tezkan, 1999). Bastani (2001) reported the tensor RMT system, EnviroMT, which was developed at the University of Uppsala, Metronix, and John Barnett & Associates Ltd. The instrument works in the frequency domain in the 1-250 kHz band, whereby the collected data can be used to study the variation of ground resistivity from the surface to a maximum depth of few hundred meters. The system is operational in two modes, the RMT and the Controlled-Source Tensor Magnetotellurics (CSTMT). The RMT method makes use of the signals generated by powerful distant radio transmitters operating in the frequency range 14-250 kHz. The CSTMT technique, with a remote controllable double magnetic dipole source covering the band 1-100 kHz, is utilized when deeper targets are aimed in low resistivity terrain studies.

## RECENT DEVELOPMENTS IN THE RADIO MAGNETOTELLURIC METHOD

The maximum antenna moment is  $6\,000\text{ A}\cdot\text{m}^2$ . The field setup is shown in Figure 5. This system uses a feedback induction coil with ferrite core to measure the magnetic field and stainless steel rods as electric field sensors. This instrument has been utilized in different near-surface applications. Tezkan and Saraev (2007) developed an RMT device, which has four channels for tensor measurements. It consists of a digital recorder and a grounded electric and magnetic antenna. The magnetic antenna is constructed using a cylinder of about 30 cm length with a multi-section coil containing a core of high permeability. The different measuring modes (time series and spectral mode) are implemented in the device. The time series of the electric and magnetic fields are recorded at two different frequency bands: D2 band (10 kHz – 100 kHz,  $\Delta f=312.5\text{ kHz}$ ) and D4 band (100 kHz – 1 MHz,  $\Delta f=2.5\text{ MHz}$ ). The system is called RMT-F1, and is shown in Figure 6. Urquhart and Schultz (2011) demonstrated their new modular system for collection of EM geophysical data. The ZEN receiver is equipped with a flexible configuration of high and low-frequency band signal conditioning and analog-to-digital converter (ADC) boards. The low-frequency band covers 300 Hz to 4 kHz, while the high-frequency band ranges up to 500 kHz. The system is capable of 6-channel continuous full speed sampling for 12 hours. Also, several magnetic field sensors were developed and tested in this system. For RMT, the ANT-6 is a good candidate, which covers magnetic field measurements from approximately 10 Hz to 500 kHz. ADU-07e is a geophysical equipment developed by Metronix. This system is capable of DC to 250 kHz measurements and can host up to 10 channels per system. Metronix's SHFT-02e has been designed for AMT, RMT and CSMT applications. It covers a frequency range from 1 kHz up to more than 300 kHz. In addition, the SHFT-02e shows outstanding low-noise characteristics, and a stable transfer function over temperature and time (Metronix, 2015).



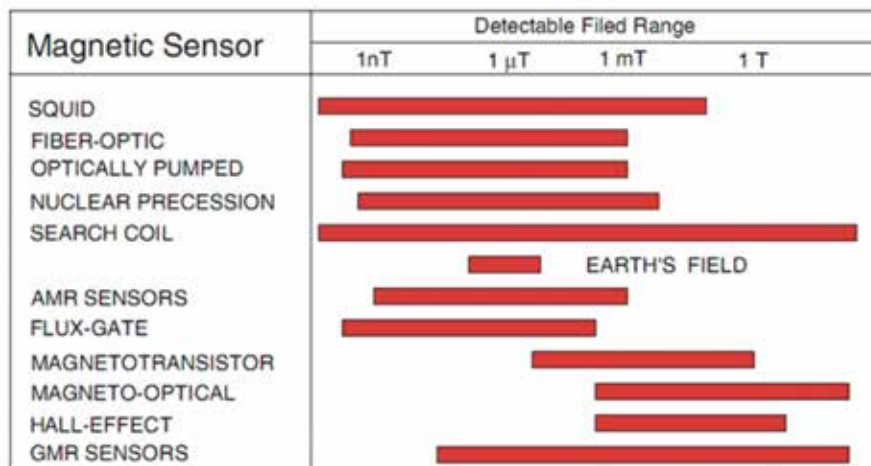
**Figure 5.** Overview and field setup of the EnviroMT system (Bastani, 2001).



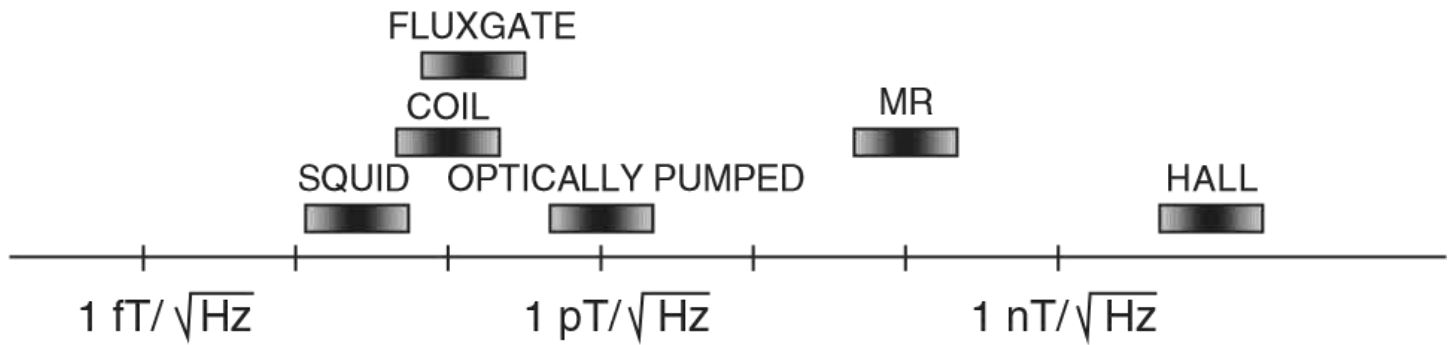
**Figure 6.** The new digital RMT-F1 system (Tezkan, 2009).

In most current RMT instruments, induction coils serve as magnetic field sensors. One reason for this is shown in Figures 7 and 8. If we examine Figure 7, one could conclude that the coil sensor is the “best” device because it covers the entire range of desired signals. However, in practice, we also compare other parameters, such as frequency range and dimension. Looking at Figure 8, it is obvious that the induction coil has more advantages compared to other sensors (Tumanski, 2007). Macnae and Kratzer (2013) pointed out that for broadband sensors and system, joint recording of B and dB/dt data derived from the same physical sensor allows for a greater number of “signal” bits that lie above sensor noise. Their field experiment data confirms the general expectation that the B-mode is suitable for low-frequency operations, while dB/dt operation is appropriate for high frequencies, and that both parameters can be collected from the same ARMIT sensor.

Grounded sensors (receiving lines of the electric field) are usually used in the RMT method for electric field measurements. However, it is easy to envisage various scenarios where it would be desirable to make electric field measurements without using ground-contact sensors. This, for example, might be in cases where the ground is extremely resistive (an outcrop), on top of a snow cover, or directly on frozen ground during winter surveys in high latitudes. Another scenario might be in a case where it is desired to attach the sensors to a moving vehicle (Macnae and McGowan, 1991). The non-contact electric field measurements have been successfully used in low-frequency electrical prospecting using the median gradient and vertical electric sounding methods, such as the Capacitive Resistivity (CR), the MUCPEP system, and the OhmMapper system (Shima et al., 1996; Auken et al., 2006; Kneisel et al., 2008; Saraev et al., 2012).

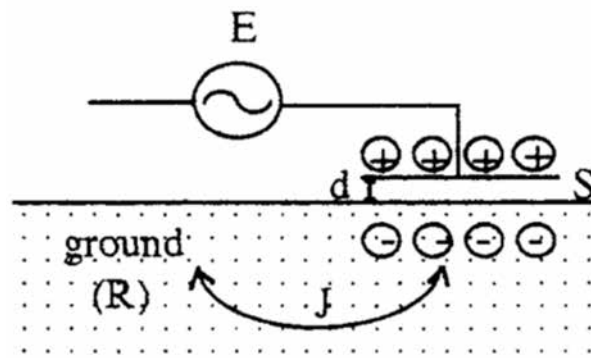


**Figure 7.** The typical field range of various magnetic field sensors (Tumanski, 2007).

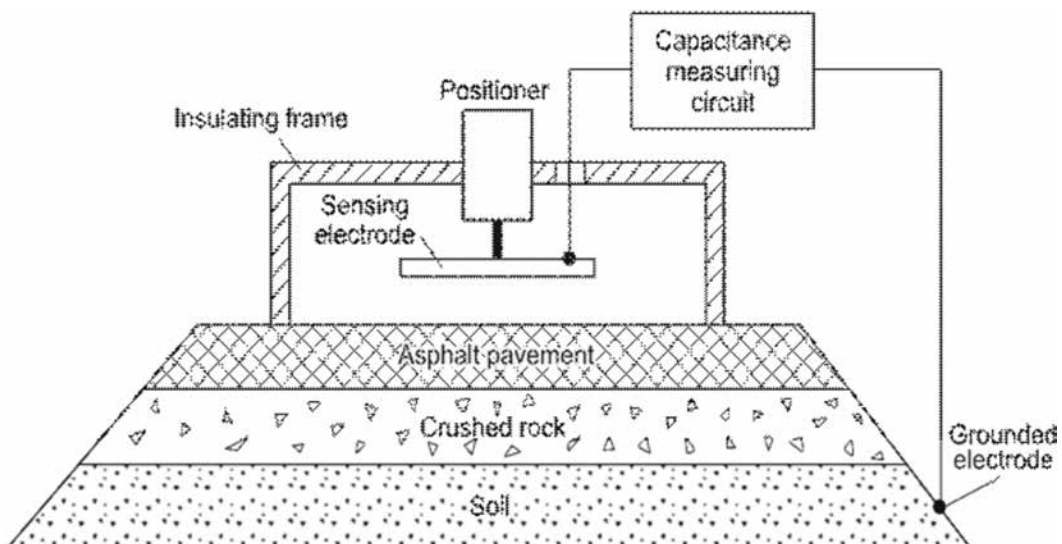


**Figure 8.** Typical resolution of various magnetic field sensors (Tumanski, 2007).

Capacitive coupling is a purely EM phenomenon, which has no temperature, ionic concentration or corrosion effects, and thus provides unprecedented measurement fidelity. The absence of an electrochemical reaction with the ground can potentially provide an operational lifetime of tens of years, even when exposed to extreme environmental conditions. Figure 9 shows the physical concepts of one type of capacitive electrode. Its actual model is shown in Figure 10 along with the capacitive electrode that works on asphalt pavements at low-frequency (~1000 Hz). The first electrode is grounded into the soil immediately adjacent to the side of the road. The second electrode is mounted on a mobile positioner that performs capacitive measurements at multiple locations along the direction perpendicular to the asphalt mat surface. This equipment with its capacitive electrodes could be used for RMT investigations. The equipment shown in Figure 10 is not designed for RMT studies, however, the fundamentals for the design and operation of this type of capacitive electrodes used at high-frequency would be similar (Adams, 2008).



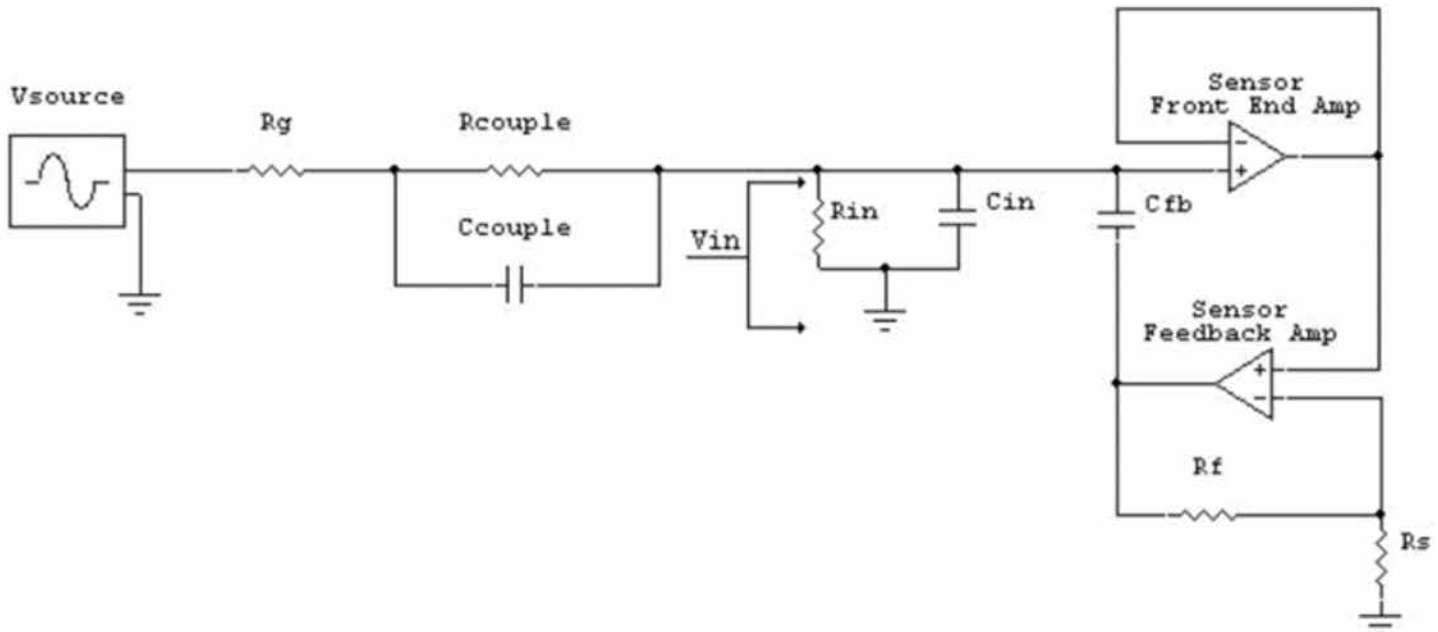
**Figure 9.** Physical concept of the capacitive electrode (Shima et al., 1996).



**Figure 10.** Schematic of a capacitance sounding array over a pavement model (Dashevsky et al., 2005).

## RECENT DEVELOPMENTS IN THE RADIO MAGNETOTELLURIC METHOD

Figure 11 is the general circuit architecture for another type of capacitive sensor. The potential of the Earth is represented by the voltage  $V_{source}$ . The sensor couples to this potential via the resistance of the Earth,  $R_g$ , and the electrode coupling impedance is represented by the components  $C_{couple}$  and  $R_{couple}$ .  $R_e$  is dominated by the ground in the immediate vicinity of the electrode while  $C_{couple}$  and  $R_{couple}$  are governed by the electrically insulating layer on the electrode. The goal is to make the sensor output independent of changes in the  $R_e$ , as much as possible, while operating in the regime of zero electrochemical coupling ( $R_{couple} = \infty$ ). The key issue with designing such a sensor is that there is no resistive path at the input to carry the amplifier input bias current. As a result, the current flows into the electrode capacitance  $C_{couple}$ , increasing the voltage at the amplifier input until it saturates. The challenge is to provide a resistive path at the amplifier input without essentially shorting the signal into the amplifier. This has been addressed by utilizing a novel patented feedback scheme (Hibbs et al, 2011).



**Figure 11.** Circuit for a capacitive electrode (note two electrodes are required to measure the E-field).  $V_{source}$  is the potential of interest,  $R_g$  is the resistance of the earth,  $C_{couple}$  and  $R_{couple}$  are the electrode contact capacitance and resistance,  $C_{in}$  and  $R_{in}$  are the amplifier input capacitance and resistance (Hibbs et al., 2011).

The first investigations with a mobile VLF-R instrument were carried out in the Soviet Union in 1970s to determine the resistivity of the rock mass for broadcasting purposes. The analog equipment developed at Leningrad State University (St. Petersburg) used magnetic and capacitive electric antennae for the determination of apparent resistivity and the moving impedance phase at one frequency in the 10-30 kHz band (Simakov et al., 2010). Simakov et al. (2010) developed a mobile RMT system which is capable of measuring the surface impedance in frequency range between 10 and 1000 kHz. They added capacitive electrodes to the RMT-F system developed in 2005 by the St. Petersburg State University, MicroKOR Ltd. and the University of Cologne. The mobile RMT system, named RMT-M, shown in Figure 12, measures one horizontal electric field component by an ungrounded electric antenna and the two horizontal magnetic field components using induction coils. The main differences between RMT-M and RMT-F are the special electric antenna attached to a vehicle, a system of sounding stations coordinates determined by a GPS recorder, and added options for data processing. A vehicle moving at a speed of five to seven km/h provides a separation of 30 to 40 m between sounding stations. Because the system only measures one electric component of an electric field (in a direction of movement), it can provide one scalar impedance. Macnae (2010) combined a charge amplifier with non-contact electric field sensors. The prototype, RMIT Electric and non-contact charge-coupled (En3c) sensors have a bandwidth of 20 Hz to 20 kHz and lower noise than 50 m grounded electrodes. Low-frequency capacitive sensors, on the other hand, are

## RECENT DEVELOPMENTS IN THE RADIO MAGNETOTELLURIC METHOD

more challenging to build, because the impedance of a capacitor tends to infinity as the frequency approaches zero. In high-frequency applications, CARIS-1, -2 and -3 have a higher frequency range. Hibbs et al. (2011) presented a new type of capacitive coupling sensor, eQube™, developed by GroundMetrics Inc. and QUASAR Federal Systems Inc. The new sensor can easily function in historically challenging, high resistance terrains including desert, frozen ground, gravel and caliche, without the need to bury electrodes, while still offering a performance equivalent to that of conventional porous pot technology. This capacitive sensor operates in low frequencies slightly smaller than 0.01 Hz and possesses a sensitivity equivalent to or better than Ag/AgCl galvanic electrodes. Saraev et al. (2012) considered the possibility of electric field measurements in the audio frequency range using capacitive (non-contact) electric sensors. These authors used ACF-4M AMT equipment, manufactured by the St. Petersburg State University and MicroKOR Ltd. The ACF-4M includes a digital recorder with four synchronous channels and a 24-bit analog-to-digital converter for each channel. The frequency range of the equipment is 0.1 to 800 Hz. They used symmetric receiving sensors with a total length of 100 m, pre-amplifiers for conditioning signals from electric sensors with a high input resistance in the range 40-200 M $\Omega$ , and robust processing of measured data to decrease the influence of noise arising from using pre-amplifiers with a high input resistance. Although the applications of ungrounded electrodes are in AMT, the results suggest that this technique will also work for RMT studies if some modifications are made to the capacitive electrodes. Hördt et al. (2013) studied the contact impedance of grounded and capacitive electrodes, and developed a method to calculate the impedance of a spherical disc over a homogeneous half-space. They carried out modeling studies to demonstrate the consistency of the algorithms and to assess conditions under which the determination of the electrical parameters from the impedance may be feasible. For a capacitively coupled electrode, the common assumption of an ideally conducting full-space (or half-space) breaks down if the displacement currents in the full-space become as large as the conduction currents. In that case, full equations, not ideal conductor equations, have to be used to estimate the electrode impedance. Such is the case in a moderately resistive medium (about 1000 Ohm-m) and frequencies larger than 100 kHz. The transition from a galvanically coupled disc to a disc in the air is continuous as function of distance. However, depending on the electrical properties and frequency, the impedance could vary by several orders of magnitude within a distance of a few nanometers or less. The impedance of capacitive electrodes increases monotonically with distance, which means an electrode in the air cannot have a smaller impedance than that of the same electrode lying on the ground. The transition from a galvanically coupled electrode towards a capacitively coupled electrode is continuous, which indicates that lifting a grounded electrode from the ground gradually will have a continuous impedance variation.



**Figure 12.** Measuring block formed by two horizontal magnetic antennae, electric signal preamplifier and electric antenna (Simakov et al., 2010).

It is clear that capacitively coupled arrays are of some interest, however, they are not problem-free. For example, in archaeological investigations, the presence of uneven surfaces will cause capacitive coupling errors (Gaffney, 2008). However, the appearance of capacitive electrodes has made it possible to collect RMT data continuously. It is evident that further developments in RMT technology should provide the opportunity to collect data faster and probe deeper into the subsurface.

### Conclusion

In recent years, RMT has seen significant progress in theory, data processing, interpretation, and instrumentation. Several 1D, 2D and 3D modeling and inversion techniques have been developed and applied in field investigations. The IPI-1000, RMT-F, RMT-M, EnviroMT, ADU-07e, and several other RMT instruments have been developed and are commercially available. These advances accelerated the use of RMT in near-surface geophysics. However, there are several challenges that must be overcome before this technique is used more widely. For example, the static phase shift will always be present in RMT measurements. Without carefully handling it, the processed data may contain large errors. With respect to data processing and interpretation, 3D modeling and inversion are still in their infancy. A fast and continuous system will decrease the cost of a geophysical field campaign. However, resolution, frequency range, and signal strength are key advantages of galvanically coupled electrodes. In contrast, capacitive sensors are not restricted to a finite set of electrode positions, thus making “continuous” spatial sampling possible. With small sampling intervals at much higher frequencies, these sensors allow for a statistically sound measurement of the impedance tensor and tipper.

### References

- Adams, C.H., 2008, Capacitive array resistivity with an inductive source: Ph.D. dissertation, RMIT University.
- Auken, E., L. Pellerin, N. B. Christensen, and K. Sorensen, 2006, A survey of current trends in near-surface electrical and electromagnetic methods: *Geophysics*, 71(5), G249-G260.
- Bastani, M., 2001, EnviroMT- a new controlled-source/radio magnetotelluric system: Ph.D. dissertation, Uppsala University.
- Bastani, M. and L.B. Pedersen, 2001, Estimation of magnetotelluric transfer functions from radio transmitters: *Geophysics*, 66(4), 1038-1051.
- Bastani, M., J. Hubert, T. Kalscheuer, L.B. Pedersen, A. Godio, and J. Bernard, 2012, 2D joint-inversion of RMT and ERT data versus individual 3D inversion of full tensor RMT data: An example from Trecate site in Italy: *Geophysics*, 77(4), WB233-WB243.
- Bastani, M., L. Persson, M. Beiki, and R. Harinen, 2013, A radio magnetotelluric study to evaluate the extent of a limestone quarry in Estonia: *Geophysical Prospecting*, 61, 678-687.
- Bastani, M., A. Malehmir, and A. Savvaidis, 2015, Combined use of controlled-source and radio magnetotelluric methods for near-surface studies: 24th International Geophysical conference and Exhibition.
- Candansayar, M.E., and B. Tezkan, 2008, Two-dimensional joint-inversion of radio magnetotelluric and direct-current resistivity data: 56, 737-749.

Cagniard, L., 1953. Basic theory of the magnetotelluric method of geophysical prospecting: *Geophysics*, 18, 605-635.

Carbajal, M.R., N. Linde, and T. Kalscheuer, 2012, Focused time-lapse inversion of radio and audio magnetotelluric data: *Journal of Applied Geophysics*, 84, 29-38.

Commer, M., and G.A. Newman, 2008, New advances in three-dimensional controlled-source electromagnetic inversion: *Geophys. J. Int.*, 172, 513-535.

Dashevsky Y. A., O. Y. Dashevsky, M.I. Filkovsky, and V.S. Synakh, 2005, Capacitance sounding: a new geophysical method for asphalt pavement quality evaluation: *Journal of Applied Geophysics*, 57, 95-106.

Egber, G.D., and A. Kelbert, 2012, Computational recipes for electromagnetic inverse problems: *Geophys. J. Int.*, 189, 251-267.

Gaffney, C., 2008, Detecting trends in the prediction of the buried past: A review of geophysical techniques in Archaeology: *Archaeometry*, 50, 313-336.

Gamble, T.D., W.M. Goubau, and J. Clarke, 1979, Magnetotelluric with a remote reference: *Geophysics*, 44, 53-68.

Geometrics, 2015, Stratagem, <http://www.geometrics.com/geometrics-products/geometrics-electromagnetic-products/stratagem/>

Goldstein, M.A., D.W. Strangway, 1975, Audio frequency magnetotelluric with a grounded electric dipole source: *Geophysics*, 40, 669-683.

Hennessy, L., 2015, Natural field electromagnetics using a partially known source: Improvements to signal-to-noise ratios: 24th International Geophysical conference and Exhibition.

Hennessy, L., and J. Macnae, 2015, Time series processing of natural source electromagnetic data using global lightning location networks: 2015 SEG Annual Meeting, 973-977.

Hibbs, A., T. Petrov, S. Milberger, G. Eiskamp, and J. Pendleton, 2011, Capacitive electric field sensors, for electromagnetic geophysics, <http://www.groundmetrics.com/downloads/>, accessed 12-9-2015.

Hordt A., P. Weidelt and A. Przyklenk, 2013, Contact impedance of grounded and capacitive electrodes: *Geophys. J. Int.*, 193, 187-196.

Ismail, N., 2009, Controlled-source Radio Magnetotelluric (CSRMT) applications in environmental and resource exploration: Ph.D. dissertation, Uppsala University.

Kalscheuer, T., L.B. Pedersen, and W. Siripunvaraporn, 2008, Radio Magnetotelluric two-dimensional forward and inverse modelling accounting for displacement currents: *Geophys. J. Int.*, 175, 486-514.

Kneisel, C., C. Hauck, R. Fortier, and B. Moorman, 2008, Advances in geophysical methods for permafrost investigations: *Permafrost and Periglacial Processes*, 19, 157-178.

Linde, N., and L.B. Pedersen, 2004, Evidence of electrical anisotropy in limestone formations using the RMT technique: *Geophysics*, 69(4), 909-916.

Macnae J. and P. McGowan, 1991, Quantitative resistance and capacitive electrodes: New developments in inductive source resistivity: *Exploration Geophysics*, 22, 251-256.

Macnae J., 2010, Electric field measurements in air: 2010 SEG Annual Meeting, 1773-1777.

Macnae, J., and T. Kratzer, 2013, Joint sensing of B and dB/dt responses: 23rd international geophysical conference and exhibition, 1.

Metronix geophysics, 2015, AUD-07e-Overview, <http://www.geo-metronix.de/mtxgeo/index.php/adu-07e-logger>.

Neukum, C., C. Grutzner, R. Azzam, and K. Reicherter, 2010, Mapping buried Karst features with capacitive-coupled resistivity system (CCR) and ground penetrating radar (GPR) in B. Andreo, F.

Carrasco, J. J. Duran, J. W. LaMoreaux, *Advances in Research in Karst Media*, Springer, 429-434.

Newman G.A., S. Recher, B. Tezkan, and F.M. Neubauer, 2003, 3D inversion of a scalar radio magnetotelluric field data set: *Geophysics*, 68(3), 791-802.

Mueller, I., 1983, Anisotropic properties of rocks detected with electromagnetic VLF: *Internat Symp., Field Measurements in Geomechanics, Special Publ.*, 273-282.

Niu Q., Y.H. Wang, and K. Zhao, 2014, Evaluation of the capacitively coupled resistivity (line antenna) method for the characterization of vadose zone dynamics: *Journal of Applied Geophysics*, 106, 119-127.

Pedersen, L.B., 1982, The magnetotelluric impedance tensor - Its random and bias errors: *Geophys. Prosp.* 30, 188-210.

Pedersen, L.B., and M. Gharibi, 2000, Automatic 1-D inversion of magnetotelluric data: Finding the simplest possible model that fits the data: *Geophysics*, 65(3), 773-782.

Pedersen, L.B., and M. Engels, 2005, Routine 2D inversion of magnetotelluric data using the determinant of the impedance tensor: *Geophysics*, 70(2), G33-G41.

Ritter, O., A. Junge and G.J.K. Dawes, 1998, New equipment and processing for magnetotelluric remote reference observations: *Geophys. J. Int.*, 132, 535-548.

Saraev, A.K., M. I. Pertel, V.G. Ivochkin, and P.M. Kostkin, 1999, Electromagnetic investigations for the solution of engineering and environment problems with use of radio stations and electro-transfer lines fields: 5th EEGS-ES Meeting, EMP-07.

Saraev, A.K., A.B., Nikiforov, N.E. Romanova, and I.S., Eremin, 2012, Possibilities of Electric field measurements in the audio frequency range using ungrounded electric sensors: *Seismic Instruments*, 48, 209-213.

Shima H., S. Sakashita, and T. Kobayashi, 1996, Developments of non-contact data acquisition techniques in electrical and electromagnetic explorations: *Journal of Applied Geophysics*, 35, 167-173.

Simakov, A., A. Saraev, N. Antonov, A. Shlykov and B. Tezkan, 2010, Mobile and controlled-source modifications of the radio magnetotelluric method and prospects of their application in the near-surface geophysics: 20th Workshop Abstract, IAGA WG 1.2 on Electromagnetic Induction in the Earth.

Smirnov, M., T. Korja, L. Dynesius, and L. B. Pedersen, 2008, Broadband magnetotelluric instrument for near-surface and lithospheric studies of electrical conductivity: A Fennoscandian pool of magnetotelluric instruments: *Geophysics*, 44, 31-44.

Song, Y., H.J. Kim, and K.H. Lee, 2002, High-frequency electromagnetic impedance method for subsurface imaging: *Geophysics*, 67(2), 501-510.

Sudha, B. Tezkan, and B. Siemon, 2014, Appraisal of a new 1D weighted joint-inversion of ground based and helicopter-borne electromagnetic data: *Geophysical Prospecting*, 62, 597-614.

Terraplus, 2015, Technical test of CORIM in France: continuous resistivity imaging system, <http://www.terraplus.com/ch/corim/corimtech.aspx>.

Tezkan, B., 1999, A review of environmental applications of quasi-stationary electromagnetic techniques: *Surveys in Geophysics*, 20, 279-308.

Tezkan, B., S. Recher, M. Honig, and F. M. Neubauer, 2001, Joint application of radio magnetotelluric (RMT) and Induced polarization (IP) to a waste site exploration: Symposium on the application of geophysics to engineering and environmental problems 2001, LWS2.

Tezkan, B., A. Saraev, 2007, A new radio magnetotelluric device for environmental geophysics operating in the frequency range from 10kHz - 1MHz: 20th EEGS symposium on the application of geophysics to engineering and environmental problems, 1187-1192.

Tezkan, B., 2009a, Application of radio magnetotelluric on geomorphological studies: Near-surface 2009-15th EAGE European meeting of environmental and engineering geophysics, 35-38.

Tezkan, B., 2009b, Radio Magnetotellurics, in R. Kirsch, *Groundwater Geophysics: A tool for Hydrogeology*, Springer, 295 - 317.

Tumanski, S., 2007, *Induction coil sensors - A review*: Institute of Physics Publishing, 18, R31-R46.

Turberg, P., I. Muller, and F. Flury, 1994, Hydrogeological investigation of porous environments by radio magnetotelluric resistivity (RMT-R 12-240 kHz): *Journal of Applied Geophysics*, 31, 133-143.

Urquhart, S., and A. Schultz., 2011, Broadband, high resolution receiver for electromagnetic investigations: GEM Beijing 2011: International workshop on Gravity, Electrical & Magnetic Methods and Their Applications.

Vozoff, K., 1991, The magnetotelluric method, in M.N., Naghibian, *Electromagnetic methods in applied geophysics*, Vol. 2, Soc. Expl. Geophys., 641-711.



*Geological Mapping  
Archaeological Investigation  
Groundwater Exploration  
Site Characterization  
Contaminant Detection  
Metal/Ordnance Detection*

## **Geophysical Instrumentation for Engineering and the Environment**

*Electromagnetic (EM) geophysical methods provide a simple, non-destructive means of investigating the subsurface for an understanding of both natural geologic features and man-made hazards, including bedrock fractures, groundwater contamination, buried waste and buried metal.*

*An advance knowledge of subsurface conditions and associated hazard potential allows for the design of remediation and monitoring programs that are more efficient and, as a result, more cost-effective.*

*Simple and non-destructive. Efficient and cost-effective.*



### **GEONICS LIMITED**

8-1745 Meyerside Dr., Mississauga  
Ontario, Canada L5T 1C6  
Phone: 905 670 9580  
Fax: 905 670 9204  
Email: [geonics@geonics.com](mailto:geonics@geonics.com)  
[www.geonics.com](http://www.geonics.com)



Mount Sopris Instruments  
is a leading manufacturer  
of borehole geophysical logging systems  
for GROUNDWATER,  
ENVIRONMENTAL,  
GEOTECHNICAL, ENERGY  
and RESEARCH industries.

**PROBES**  
**WINCHES**  
**LOGGERS**  
**SOFTWARE**

Learn more at  
**MOUNTSOPRIS.COM**



**BOREHOLE LOGGING SYSTEM SALES AND RENTALS**

# INDUSTRY NEWS

## **Sensors & Software Inc. Announces the LMX200 - The Premier GPR Utility Locating Tool in the Market Today -**

Sensors & Software Inc. announces the launch of the LMX200, the Premier Ground Penetrating Radar utility locating tool in the market today.

The LMX200 is designed specifically to make marking utilities with GPR simple and easy, offering the perfect balance of depth penetration and resolution for accurate locating. Unlike conventional cable locating devices, the LMX200 can detect non-metallic utilities, including plastic and concrete pipes and structures, as well as metallic targets.

Data collected provides a real-time subsurface image to detect utilities and pinpoint and mark their locations. Surveys are processed quickly on-site to produce plan maps with geo-tagged field interpretations and the ability to wirelessly e-mail basic reports, right from the field.

The revolutionary Dynamic target enhancement, DynaT, acts like 3 GPRs in one by easily allowing users to toggle between display views enhancing small, medium and large targets. Along with the ability to acquire data, the LMX200 allows the user to assign colour classifications directly on the touchscreen in real time as utilities are located.

### Additional features include:

- High resolution cross-sectional views.
- Wi-Fi transfer of images in real time.
- Instant reports of screen captures and line/grid/cross view information.
- High resolution touchscreen.
- Data download to a PC for processing, image generation and advanced reporting capabilities.

The LMX200 provides simple real-time locating capability in a compact and easy to use system, and provides enormous enhanced capabilities in a system designed specifically with professional utility locators, engineers and surveyors in mind. Contact Sensors & Software by phone at 1-800-267-6013 or visit [gprlocates.com](http://gprlocates.com) for more information.



### **About Sensors & Software Inc.**

Sensors & Software delivers subsurface imaging solutions and training to customers worldwide. Understanding what lies beneath the surface of materials like soil, rock, rubble, pavement, concrete, water, ice and snow opens endless possibilities. The combination of our diverse expertise, years of experience, world-leading products and responsive customer service enables delivery of practical and effective solutions that meet the needs of our customers. In a deeply specialized scientific and technical field, the focus is always to make complex challenges faced by our customers simpler and easier to tackle by using the most advanced instrumentation and integrated software.

We are focused on bringing value and innovation to your organization by allowing you to see beyond the surface. Through our extensive dealer network and global offices, Sensors & Software Inc. is equipped to provide your product, software, and training solutions.

# INDUSTRY NEWS

## geoDRONE Report

©2016 Aerobotic Geophysical Systems, LLC

by R. Bell

31 December 2015

Remotely piloted aircraft systems (RPAS) *will* impact your work life. If you have not experienced it yet, expect it to happen in 2016. The rise in the consumer use of quadcopter aircraft is nothing short of dramatic. On December 23<sup>rd</sup>, 45,000 brand new drone pilots jammed the FAA registration website so hard that it was forced to “*shut down for maintenance*”. But the most important drone event in 2015 impacting the air space of the United States is the introduction of the Exemption 333 ruling for obtaining a Certificate of Authorization (COA). Upon being awarded a COA, individuals and companies are legally permitted to operate small unmanned aircraft systems (sUAS) for profit. For a modest investment, it is possible for a geologically-minded drone pilot to acquire geospatial and geoscientific data and information about the surface *and* the subsurface of the earth. However, to do so cost effectively requires experience, UAS operational training and knowledge, and, quite often, an industrial grade aircraft and sensor package.

In 2015, I became aware of the following companies and thought you might like to know about them. The commonality of each is that they are using small UAS for geospatial and geoscientific data acquisition.



MGT offers a magnetic and radio frequency EM data acquisition services employing multi-rotor and fixed wing small UAS. Dr. Stoll has developed a unique UAS magnetometer data acquisition based on a 3-axis fluxgate magnetometer with sensitivity of 0.5 nT.



Earth Forensics is a multi-dimensional environmental and hydrogeological consulting and services company based in southern California. EF pioneered the commercial use blimps for aerial geology. They received one of the first Exemption 333 COA's and have logged hundreds of hours acquiring visible light, NIR, and TIR photogrammetry data for geologic and geologic hazards mapping, surface and groundwater studies, and construction asset management.

### Front Range UAS Services

The primary business for Front Range UAS is to provide UAS imagery to agronomists focused on precision agriculture. The company recently added a heavy lift octocopter capable of lifting a 10 lb. payload with flight times in excess of 30 minutes. The company offers mission services for geophysical and air quality data acquisition.

contact: Dr. Johannes B. Stoll, President  
tel: +49 (05141) 88 93 650  
e-mail: [jstoll@mgt-geo.com](mailto:jstoll@mgt-geo.com)  
location: Celle, Germany  
website: <http://mgt-geo.com>  
UAS Operated: a) various multi-rotor copters  
b) fixed wing sUAS by Hanseatic  
Sensors: a) magnetometer  
b) radio frequency EM

Contact: Rene Perez, CHG Senior Hydrogeologist  
tel: (714) 612-3046  
e-mail: [rperez@earthforensics.com](mailto:rperez@earthforensics.com)  
location: N. Tustin, CA  
website: <http://earthforensics.com/>  
UAS Operated: a) DJI Quadcopter  
Sensors: a) visible light camera  
b) near infrared  
c) thermal infrared

Contact: Christopher Rice UAS Pilot & GIS Analyst  
tel: (303) 990 -7900  
e-mail: [chris@fronrangeuas.com](mailto:chris@fronrangeuas.com)  
location: Wheat Ridge, CO  
website: <http://www.fronrangeuas.com/>  
UAS Operated: a) Agribotix Enduro Quad  
b) DJI F550 Hexrotor  
c) Carbon Core X8  
Sensors: a) visible light camera  
b) near infrared  
c) thermal infrared

# INDUSTRY NEWS

## geoDrone Report - continued

Dear Reader:

I plan on providing a geoDRONE Report for the next and subsequent issues of FastTIMES. If you have news and information regarding drone relevant technology or drone services or, perhaps, the business of applying drones for geological and other “geo-“ investigations and wish to share with it the readers of this report, please feel free to e-mail it to me at [rbell@igsdenver.com](mailto:rbell@igsdenver.com).

I also invite you to send along your comments and suggestions. My goal is to convey timely and relevant information to anyone with an interest in using drones for geological and geospatial mapping as well as to geoscience professionals presently or seeking to be engaged in the practice of acquiring geoscientific and geospatial data using autonomously operated robotic vehicles.

Of course, keep in mind that space limitations and suitability may restrict what I am able to include in the report. However, if you take the time to provide me with content, I will do my best to include it.  
Thank you for reading. – Ron Bell

1 Day Short Course

# geoDRONEology

March 20, 2015  
Denver, CO

**Special Bundle Pricing!**

**Save \$110 when you register for SAGEEP Monday Sessions & geoDRONEology!!!**

for more info: [www.eegs.org/SAGEEP-2016](http://www.eegs.org/SAGEEP-2016)



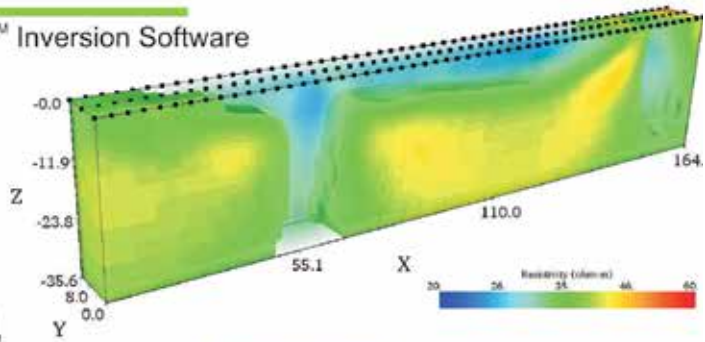
# AGI *Advanced Geosciences, Inc.*

Resistivity Imaging Systems and EarthImager™ Inversion Software

- Rentals
- Sales
- Tech support
- Training
- Repair
- Data

We offer complete imaging systems to perform remote monitoring, VES, Archelological, Geotechnical, Geophysical, Geological and Mining surveys.

Our products: SuperSting™ and MiniSting™ resistivity instruments, EarthImager™ 1D, 2D, 3D and 4D inversion modeling software.



 *Advanced Geosciences Europe, S.L.*

**EUROPEAN OFFICE:**

Advanced Geosciences Europe, S.L.  
Calle del Siroco 32,  
28042 Madrid, Spain  
Teléfono: +34 913 056 477  
Fax: +34 911 311 783  
Email: age@agiusa.com  
Web: www.agiusa.com

 *Advanced Geosciences, Inc.*

**MAIN OFFICE:**

Advanced Geosciences, Inc.  
2121 Geoscience Dr.  
Austin, Texas 78726 USA  
Tel: +1 512 335 3338  
Fax: +1 512 258 9958  
Email: agi@agiusa.com  
Web: www.agiusa.com



## Seismic Accessories



**Land Streamers—for efficient seismic surveys**



**Rollalong Switches  
24, 48 & 96 channel**

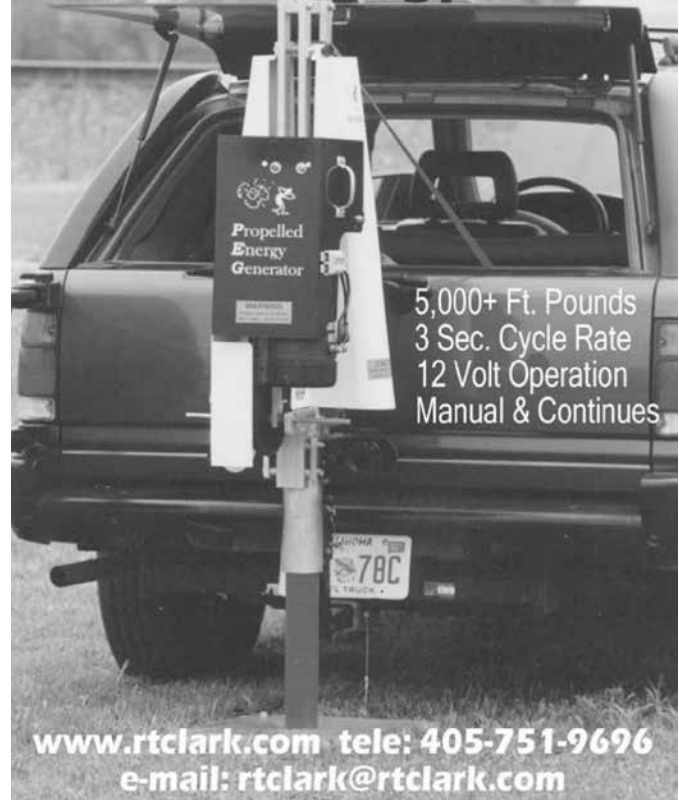
**Wall-Lock  
Borehole  
Geophones**



**Geostuff**

<http://www.geostuff.com>  
Tel 530-274-4445, fax 530-274-4446

## PEG-40 Portable Energy Source



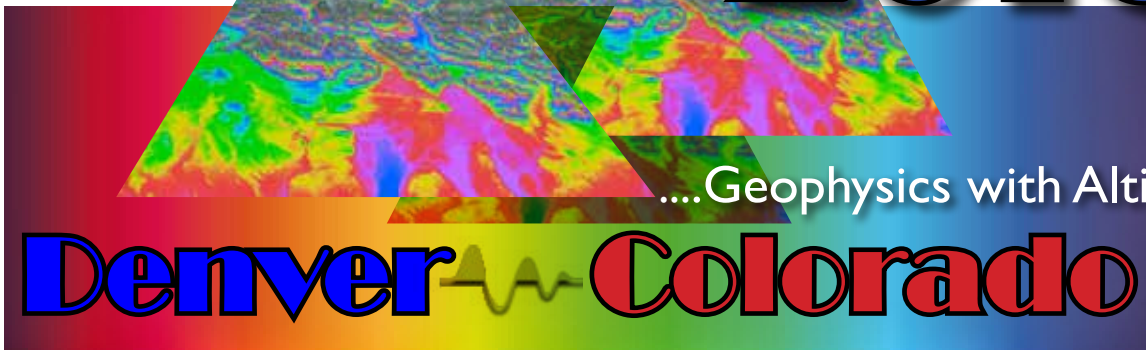
5,000+ Ft. Pounds  
3 Sec. Cycle Rate  
12 Volt Operation  
Manual & Continues

[www.rtclark.com](http://www.rtclark.com) tele: 405-751-9696  
e-mail: [rtclark@rtclark.com](mailto:rtclark@rtclark.com)

# COMING EVENTS AND ANNOUNCEMENTS

# SAGEEP

# 2016



...Geophysics with Altitude

## Denver Colorado

## MARCH 20-24

### Marriott City Center | Downtown Denver

[www.EEGS.org/Annual Meeting/SAGEEP 2016](http://www.EEGS.org/Annual Meeting/SAGEEP 2016)

Online Registration Open! Register Now and Assure Your Spot in These Sessions:

<p>Agricultural Geophysics Airborne Geophysics &amp; Remote Sensing Archaeological Geophysics Engineering Geophysics Geophysics and Geologic Hazards Hydrogeophysics/Geophysics Applied to Water Resources Geophysics in Climate and Critical Zone Studies Geophysics for Contaminant and Site Remediation Borehole Geophysics</p>	<p>Geophysics in the Oilfield: Contaminants, Water Demand, Induced Seismicity, and Hydraulic Fracturing Highway Geophysics Integrated Near Surface Geophysics Case Histories Mining and Reclamation Geophysics Transportation and Infrastructure Geophysics UXO and UXO Sensor Technology Drones in Geophysics</p>	<p>Electromagnetics and Magnetotellurics GPR and EMI in Complex Environments GPR Instruments Gravity &amp; Magnetic Methods: Engineering &amp; Environmental Applications HVSr and Passive Seismology Integrating Drones into Geophysical and Geological Mapping Projects Novel Environmental/NS Geophysical Methods</p>	<p>Near Surface Geophysical Data Analyses, Integration, &amp; Processing Near Surface Geophysics across Hydrologic Interfaces Shallow Marine &amp; Underwater Geophysics Near Surface Seismic Reflection and Refraction NMR for Near-surface Investigations Resistivity/Induced Polarization/Self-Potential Methods and Applications</p>
--------------------------------------------------------------------------------------------------------------------------------------------------------------------------------------------------------------------------------------------------------------------------------------------------------------------------------------------------------------------	--------------------------------------------------------------------------------------------------------------------------------------------------------------------------------------------------------------------------------------------------------------------------------------------------------------------------------------------	--------------------------------------------------------------------------------------------------------------------------------------------------------------------------------------------------------------------------------------------------------------------------------------------------------------------------------------------------	--------------------------------------------------------------------------------------------------------------------------------------------------------------------------------------------------------------------------------------------------------------------------------------------------------------------------------------------------------------

....And Your Spot in These Short Courses:

#### Short Courses Sunday, March 20 (Full Day)

##### SC-1: geoDRONEology

Presenters: Ronald S. Bell, Aerobotic Geophysical Systems, LLC; Rene A. Perez, PG, CHG, Senior Consultant, Hydrogeology, earthforensics, inc.

##### SC-2: Ground Penetrating Radar - Principles, Practices and Processing

Presenter: Greg Johnston, Sensors & Software, Inc.

#### Short Courses Thursday, March 24 (Full Day)

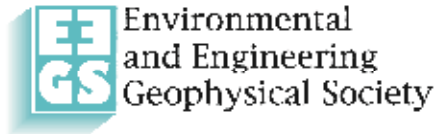
##### SC-3: Satellite InSAR Data: Surface Deformation Monitoring from Space

Presenter: Alessandro Ferretti (special EAGE-sponsored EET course)

##### W-1: Summit on Dams and Levees

Presenters: William Doll, Tetrattech; Phil Sirles, Olson Engineering

# COMING EVENTS AND ANNOUNCEMENTS



Announcing.....

## [SAGEEP 2016 Short Courses/Workshops](#)

Registration information available soon! Access the [SAGEEP website](#) for rates and online registration links.

### Sunday, March 20, 2016

#### **SC-1: geoDRONEology © 2015 Aerobotic Geophysical Systems, LLC A ONE DAY SHORT COURSE ON INTEGRATING DRONES INTO THE GEOSCIENTIFIC AND ENGINEERING WORKFLOW**

**Presenters:** Ronald S. Bell, Senior Geophysicist, President, Aerobotic Geophysical Systems, LLC; Rene A. Perez, PG, CHG, Senior Consultant, Hydrogeology, earthforensics, inc.

Multi-rotor and fixed-wing autonomous robotic aircraft, commonly known as “drones”, are the latest technical innovation being applied to the acquisition of geospatial and geoscientific data for asset management, geological investigations, and environmental monitoring. This short course will provide you with up-to-date information on how to begin using small unmanned aircraft systems (sUAS) equipped with visible light and infrared cameras for surface investigations and magnetometers for subsurface site characterization. A strong emphasis is placed on the practical implementation of drones for photogrammetry, infrared and spectral imaging, and magnetometry through the use of numerous case histories. Recent changes in the rapidly evolving regulatory framework governing sUAS including the recommended best practices for legally operating drones for profit will be reviewed.

There will be a “wrap up discussion” on the several issues of concern including but not limited to a) the implementation of detect and avoid technologies, b) beyond line of site operations, c) night time flights, and d) drone swarms.

#### **SC-2: GROUND PENETRATING RADAR - PRINCIPALS, PRACTICES AND PROCESSING**

**Presenter:** Greg Johnston, Sensors & Software, Inc.

Ground Penetrating Radar (GPR) is a non-invasive subsurface exploration technique that has found widespread application in areas including near-surface geology (<100 meters), geotechnical and environmental surveys, mine safety, forensics, archaeology, utility location, concrete inspection, snow thickness measurements and glaciology. This one day course will introduce the principles of GPR and GPR instrumentation, discuss survey design, provide hands-on data acquisition with a GPR system and explore data interpretation (including common pitfalls), data processing and data visualization in 2D and 3D. The course also includes case studies of common and not-so-common applications of the

# COMING EVENTS AND ANNOUNCEMENTS

## [SAGEEP 2016 Short Courses/Workshops - continued](#)

technology. No prerequisites required. Students will receive printed course notes and a memory stick with a PDF copy of a GPR textbook written by Dr. Peter Annan, the CEO and founder of Sensors & Software. Attendees need to come prepared to work for 2-3 hours outside and, if interested, bring a PC-based laptop for the data processing portion of the course. The laptop should have GoogleEarth installed, if possible.

### **THURSDAY, March 24, 2016**

#### **SC-3: SUMMIT ON DAMS AND LEVEES**

**Presenters:** William Doll, Tetrattech; Phil Sirles, Olson Engineering

It is now widely recognized that the infrastructure in the US is in poor condition, and this is but one example of a larger global problem for public safety. Dams and levees, often constructed in an era of less stringent design and construction requirements, are among the infrastructure elements that are of great concern; particularly, as populations increase and relocate in proximity to formerly remote dam and/or levee structures. Geophysics offers many tools that can be used for large-scale assessment and internal imaging, as well as more localized subsurface material characterization of problem areas. Many geophysical and advanced monitoring methods have been developed and deployed and in countries throughout the world.

This forum on dams and levees is designed to bring together geophysicists from many countries to a common venue to share knowledge and experience, as well as discuss the future needs that our industry can provide for addressing this critical problem. The forum includes speakers from leaders in industry, government, and commercial application of state-of-the-practice methods and advancements to state-of-the-art for imaging and monitoring small and large structures with remote/satellite, heliborne, driven, and handheld instruments, which can be deployed once or installed for monitoring these structures.

#### **SC-4: SATELLITE INSAR DATA: SURFACE DEFORMATION MONITORING FROM SPACE**

**Presenter:** Alessandro Ferretti, TeleRilevamento Europa Milan, Italy (special EAGE-sponsored EET course)

Satellite radar data for surface deformation monitoring are gaining increasing attention, and not only within the oil and gas community. They provide a powerful tool for remotely measuring extremely small surface displacements over large areas and long periods of time, without requiring the installation of in-situ equipment. However, apart from remote sensing and radar specialists, only a relatively small number of geoscientists and engineers understand how a radar sensor orbiting the Earth at about 7 km/s from 700km above the Earth's surface can actually measure ground displacements of a fraction of a centimeter.

This course provides a step-by-step introduction to satellite radar sensors, SAR imagery, SAR interferometry and advanced InSAR techniques. Rather than a tutorial for remote sensing specialists, the course starts from very basic concepts and explain in plain language the most important ideas related to

# COMING EVENTS AND ANNOUNCEMENTS

## [SAGEEP 2016 Short Courses/Workshops - continued](#)

SAR data processing and why geoscientists and engineers should take a vested interest in this new information source.

Instead of providing a thorough analysis of InSAR algorithms, the main aim of the course is to diffuse the news about the potential impact of InSAR results on many real-life applications, highlighting where and when they can provide effective solutions. Participants will learn that InSAR is not only an information source for research and development activities, but also a reliable tool that can be applied successfully to many different applications, spanning from sinkhole detection to reservoir optimization.

Special attention will be paid to oil and gas applications where surface deformation data can provide valuable constraints on reservoir dynamics, enabling time lapse monitoring of volumetric strains at depth. Volume changes in the reservoir induced by fluid extraction and injection can induce both subsidence and uplift. Stress changes may then trigger the reactivation of faults and threaten well integrity. Depending on the depth of the reservoir and the characteristics of the cap rock, deformation may also be detectable at the surface.

---

## **Ground Truthing and Geophysics for Offshore Engineering**

A year on from the EAGE's Applied Shallow Marine Geophysics conference in Barcelona the SUT will hold its 8th international conference - 'Smarter Solutions for Future Offshore Developments'. The event will take place from 12th to 14th September 2017 at the historic Royal Geographical Society and Natural History Museum in South Kensington London under the direction of the Offshore Site Investigation and Geotechnics (OSIG) group who have again requested input from the EAGE.

The conference series, which has run since 1979, offers a unique opportunity for geotechnical engineers, geoscientists and academics specialising in offshore topics to share their knowledge and experience. In addition to hosting the prestigious McClelland Lecture, the 2017 conference will focus on new research and developments in site investigation data acquisition, evaluation and integration, geotechnical analysis and design as well as field operational experience. A Special Issue of the EAGE Near Surface Geophysics journal will be published preceding the conference with selected papers to be presented at a session on shallow geophysics. The aim is to expand significantly the boundaries of knowledge and practice in offshore geotechnics and geoscience and emphasise their complementary nature.

The challenges currently faced by the offshore oil & gas industry call for innovative approaches to improve efficiency and rigour in practice, while the offshore renewable energy industry has identified and addressed through major research programmes the

# COMING EVENTS AND ANNOUNCEMENTS

## **Ground Truthing and Geophysics for Offshore Engineering - continued**

key technical issues that must be solved to support its growing strength. High profile international incidents have also occurred across all sectors in recent years that posed significant data acquisition, engineering and operational challenges.

The SUT and the EAGE are calling for high quality papers that report on the above topics and other developments, set out new research findings and present innovative ideas as to how the sector can improve efficiency, develop more collaborative approaches and offer innovation towards Smarter Solutions for Future Offshore Developments.

Instructions for conference paper abstracts with conference themes are detailed below. Authors whose abstracts are subsequently selected for possible inclusion as a full manuscript in the EAGE Near Surface Geophysics Special Issue should see 'Guidance for Authors' at [www.nsg.eage.org](http://www.nsg.eage.org) and <http://mc.manuscriptcentral.com/nsg>.

### Call for Papers

- 200 word abstracts should be submitted in English and in 'Microsoft Word' format, using the abstract template which can be downloaded from [www.sut.org/event/osig2017](http://www.sut.org/event/osig2017). Please do not send 'pdf' format abstracts.
- All abstracts should be emailed to [osig2017@sut.org](mailto:osig2017@sut.org) no later than 29th February 2016; a notice of receipt will be emailed by return.
- All primary authors will be notified of their abstract status by 30th April 2016. Technical paper instructions to successful authors will also be provided at this time.
- Successful authors are requested to submit draft papers for review by 30th November 2016.
- Following comments, final publication quality papers are required by 30th April 2017.

To aid administration, authors are requested to select the primary categories and keywords for their abstract from the following list: shallow geology & geohazards, seabed slopes, diapirs & slides, hydrates & shallow gas, seismic hazards & tsunamis, tophole drilling & well engineering, advances in geophysical data collection (including use of AUV) & processing, geotechnical site investigation & characterisation, learning from offshore incidents to reduce ground risk, foundation research, design, construction & monitoring, data integration & ground modelling, efficiencies through optimisation & performance based design, piled foundations, suction installed foundations, gravity based foundations, jack-up rig foundations, anchoring, cyclic & seismic loading of foundations, scour assessment & monitoring, pipeline & cable seabed engineering, risers & seabed interaction, environmental & ecological impacts of seabed engineering, decommissioning and seabed clean up, working in polar environments, climate change effects, deep sea mining, monitoring & overburden integrity for carbon storage. It should be noted that these categories are tentative and the committee will consider all abstracts relevant to offshore site investigation, geophysics & geotechnics, including relevant case studies. Please indicate in your covering letter if you wish your paper to be considered for inclusion in the special issue of Near Surface Geophysics.

# COMING EVENTS AND ANNOUNCEMENTS

## CALL FOR PAPERS



The Geo-Institute Chapter of the Colorado Section of the American Society of Civil Engineers (ASCE), the Rocky Mountain Section of the Association of Environmental & Engineering Geologists (AEG), and the Colorado Association of Geotechnical Engineers (CAGE) have hosted the Geo-Conference since 1984. This conference focuses on geotechnical projects in Colorado and the Rocky Mountain Region, and is a one-day opportunity for geo-professionals to share experiences and state of the practice with their colleagues.

## IMPORTANT DATES

- **Abstract due**  
January 25, 2016
- **Author Acceptance Notification**  
February 22, 2016
- **Draft Papers for Review due**  
April 25, 2016
- **Review Comments Delivered to Authors**  
June 3, 2016
- **Final Papers due**  
July 1, 2016

### Potential Topics include

- Transportation
- Aging and Rehabilitation of Infrastructure
- Water Resources
- Innovations in Geotechnical Engineering
- Environment
- Mining and Energy
- Natural Hazards, Disasters and Recovery
- Geotechnical Risk and Reliability
- Investigation and Testing
- Instrumentation and Monitoring
- Case Histories

### Submission Instructions

Please email your abstract as text within the body of the email to Jere Strickland at [jstrickland@martineztesting.com](mailto:jstrickland@martineztesting.com) by 5:00 PM Mountain Time on January 25, 2016. With the abstract, please indicate your name, your role in the subject matter, your daytime telephone number, and your return email address. This abstract is for informal Steering Committee review, not for publication.

Papers accepted for the 2016 Rocky Mountain Geo-Conference will be published by ASCE as a Geotechnical Practice Publication (GPP) and distributed at the conference.

## EVENT INFORMATION

- **Rocky Mountain Geo-Conference**  
November 4, 2016
- **Marriott Denver West Hotel**
- **Lakewood, CO**



# COMING EVENTS AND ANNOUNCEMENTS

## Speakers

Jeff Zawila  
Johannes Douma  
Travis Pitcher  
Tony Lupo  
Jyoti Behura  
Trey Cortez  
Lee Krystinik  
Heloise Lynn  
J.B. Aldrich  
Chelsea Newgord

SM Energy  
Cimarex  
CSM - RCP  
SM Energy  
Seismic Science  
E & E Partners  
Equus Alliance  
Lynn Inc.  
MHA Petroleum Consultants  
Sigma3



**3D SEISMIC SYMPOSIUM**  
PRESENTED BY RMAG AND DGS

Colorado Convention Center  
**Thursday, March 3, 2016**

Registration, Sponsorship, Exhibitor  
registration are all open.

22nd Annual RMAG & DGS

# 3D Seismic Symposium

Focusing our Energy

## Morning Kick-Off Speaker

Ross Peebles  
Global Geophysical

## Keynote Speaker

Than Putzig  
Southwest Research

## Afternoon Kick-off Speaker

Boak/Shemeta  
Oklahoma Geological Survey

[www.3dseismicsymposium.com](http://www.3dseismicsymposium.com)

email: [staff@rmag.org](mailto:staff@rmag.org) | phone: 303.573.8621 | fax: 303.476.2241 | web: [www.rmag.org](http://www.rmag.org)  
910 16th Street #1214, Denver, CO, 80202 | follow: @rmagdenver



# COMING EVENTS AND ANNOUNCEMENTS

## **USGS - OGW Branch of Geophysics**

### **Notification of Potential Postdoc Position**

**04 December 2015**

The U.S. Geological Survey (USGS), Office of Groundwater, Branch of Geophysics (<http://water.usgs.gov/ogw/bgas/>), anticipates an opening for a postdoctoral researcher in the area of hydrogeophysics. The purpose of this notice is to seek prospective applicants for this opportunity. The anticipated start date for this position is mid-to-late 2016, pending final approval and funding availability.

The Branch of Geophysics engages in applied geophysics research and technology-transfer related to groundwater resources. Current research initiatives at the Branch include application of geophysical methods to (1) characterize aquifer systems and properties controlling fluid flow and transport; (2) monitor natural and engineered hydrologic processes; (2) understand groundwater/surface-water interaction; and (4) evaluate potential hydroecologic impacts of climate change. It is anticipated that the postdoc will work on one or more projects related to these topics and engage in fieldwork, data analysis, and publication of results. We are looking for candidates with strong quantitative skills, experience with geophysical forward and inverse modeling, programming ability in two or more computer languages, and experience with field and/or laboratory experiments. Candidates should have experience or course work in electrical and electromagnetic geophysical methods and hydrology.

The Branch of Geophysics is located on the University of Connecticut campus, in Storrs, Connecticut. The office's location on the UConn campus and in Connecticut's rural 'Quiet Corner' provides for cultural opportunities, outdoor recreation, and easy access to Hartford (~30 minutes), Boston (~1.5 hours), and New York City (~2.5 hours).

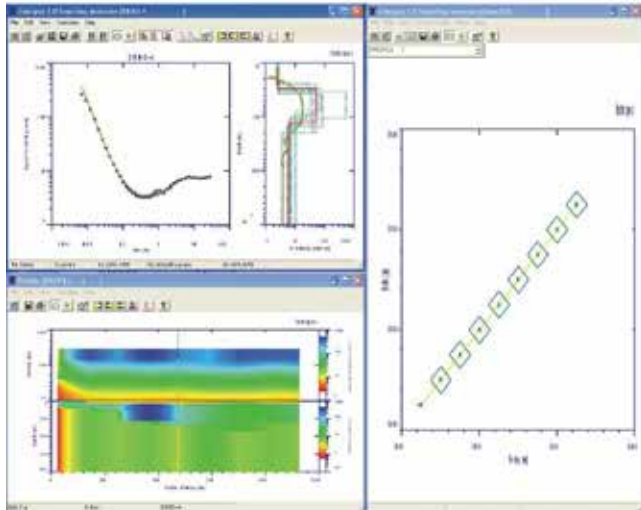
If you are interested in knowing more about this position, please contact Drs. Fred Day-Lewis ([daylewis@usgs.gov](mailto:daylewis@usgs.gov)), John Lane ([jwlane@usgs.gov](mailto:jwlane@usgs.gov)), or Martin Briggs ([mbriggs@usgs.gov](mailto:mbriggs@usgs.gov)).

U.S. Citizenship is required. The USGS is an Equal Opportunity Employer.

# Interpex Software

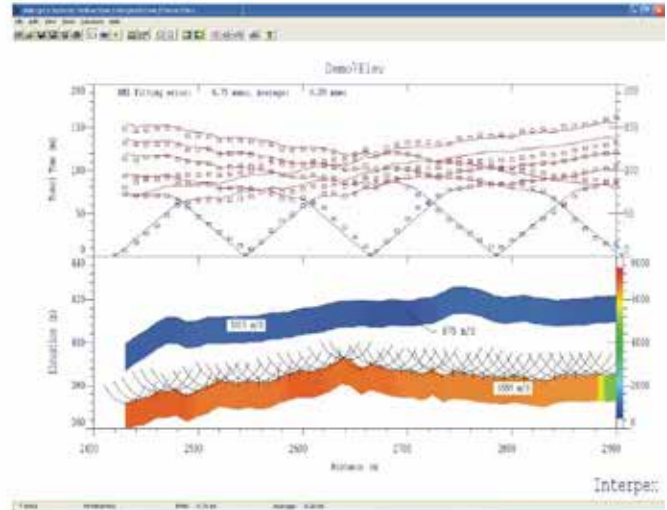
## IX1D version 3

available with or without TEM option  
1D Sounding Interpretation with profile support  
DC, IP, MT, FEM, EM Conductivity (TEM optional)



## IXRefraX

Simply the fastest and best Seismic Refraction  
Processing and Interpretation Software using  
the Generalized Reciprocal Method



P.O. Box 839  
Golden CO 80402

Tel (303) 278 9124  
Fax (303) 278 4007

www.interpex.com  
info@interpex.com



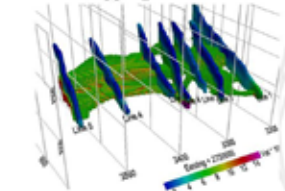
## Zonge Engineering and Research Organization, Inc.

*Celebrating 35 Years of Geophysical  
Services & Instrument Sales Worldwide*

**State-of-the-Art  
Instrumentation Sales  
and Lease**



Bedrock Mapping with 3D Seismic



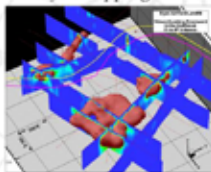
### Consulting

- ◆ Survey Design
- ◆ Data Processing
- ◆ 2D & 3D Imaging & Modeling
- ◆ Interpretation Software

### Applications

- ◆ Mineral Exploration
- ◆ Sinkholes and Cavity Detection
- ◆ Landslide Delineation
- ◆ Soil & Rock Characterization
- ◆ Aquifer Characterization
- ◆ Structure Mapping
- ◆ Groundwater Basin Mapping
- ◆ Archeological Investigations
- ◆ Contaminant Tracking
- ◆ Time-lapse Monitoring
- ◆ UXO/MEC Detection

Landfill Mapping with IP

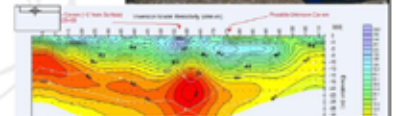


### Field Surveys

- ◆ Resistivity, IP, CR
- ◆ 2D & 3D Seismic
- ◆ TDEM & FDEM
- ◆ CSAMT & NSAMT
- ◆ Gravity and Magnetics
- ◆ Ground Penetrating Radar

Complete Line of EM Sensors, Electrical/  
EM Receivers, 3-30kW Transmitters,  
Power Generators and Customized  
Instrumentation

ZETA™ - Zonge  
Electrical Tomography Acquisition System



Void Mapping with ZETA™

**"geophysical results through continuous innovation"**

Contact Zonge at 1-800-GEOPHYSICS or any of our Regional Offices

**ARIZONA (Corporate)**  
3322 East Fort Lowell Road  
Tucson, AZ 85716  
520.327.5501  
zonge@zonge.com

**NEVADA**  
924 Greg Street  
Sparks, NV 889431  
775.355.7707  
zonge@zongenev.com

**COLORADO**  
1990 S. Garrison St., #2  
Lakewood, CO 80227  
720.962.4444  
zongecolor@zonge.com

**ALASKA**  
37029 Denise Lake Drive  
Soldotna, AK 99669  
907.262.5072  
zonge@alaska.net

**MINNESOTA**  
4700 West 77th Street  
Minneapolis, MN 55435  
952.832.2616  
zongeminn@zonge.com



## Individual Membership Categories

EEGS is the premier organization for geophysics applied to engineering and environmental problems. Our multi-disciplinary blend of professionals from the private sector, academia, and government offers a unique opportunity to network with researchers, practitioners, and users of near-surface geophysical methods.

Memberships include access to the *Journal of Environmental & Engineering Geophysics (JEEG)*, proceedings archives of the Symposium on the Application of Geophysics to Engineering and Environmental Problems (SAGEEP), and our quarterly electronic newsletter, *FastTIMES*. Members also enjoy complimentary access to SEG's technical program expanded abstracts, as well as discounted SAGEEP registration fees, books and other educational publications. EEGS offers a variety of membership categories tailored to fit your needs. Please select (circle) your membership category and indicate your willingness to support student members below:

Yes, I wish to sponsor \_\_\_\_\_ student(s) @ \$20 each to be included in my membership payment.

**Individual Members** Individual members are invited to sponsor student members. Simply indicate the number of students you'd like to support (at \$20 each) to encourage growth in this important segment of EEGS' membership.

Category	Electronic JEEG Available Online	Printed JEEG Mailed to You
<b>Individual</b>	\$90	\$130

**Retired Members** Your opportunity to stay connected and support the only organization focusing on near surface geophysics. Retired members are invited to sponsor student members. Simply indicate the number of students you'd like to support (at \$20 each) to encourage growth in this important segment of EEGS' membership.

Category	Electronic JEEG Available Online	Printed JEEG Mailed to You
<b>Retired (Must be Approved by EEGS Board of Directors)</b>	\$50	\$130

**Introductory Members** If you have not been a member of EEGS before, we offer a reduced rate (electronic JEEG option) for new members to enjoy all the benefits of individual membership (except vote or hold office) for one year.

Category	Electronic JEEG Available Online	Printed JEEG Mailed to You
<b>Introductory</b>	\$50	\$130

**Lifetime Members** New! Support EEGS, receive benefits on an ongoing basis and never renew again! Members of this category enjoy all the benefits of Individual membership.

Category	Electronic JEEG Available Online	Printed JEEG Mailed to You
<b>Lifetime Member</b>	\$995	\$995

**Developing World Members** Those wishing to join this category of EEGS membership are invited to check the list of countries to determine qualification.

Category	Electronic JEEG Available Online	Printed JEEG Mailed to You
<b>Developing World (List of qualifying countries next page)</b>	\$50	\$130

**Student Members** Students represent EEGS' future and we offer complimentary membership subsidized by Corporate Student Sponsor Members and those who sponsor students. Student members enjoy all the benefits of individual membership (except to vote or hold office). Available for all students in an accredited university up to one year post-graduation. Please submit a copy of your student ID and indicate your projected date of graduation: \_\_\_ / \_\_\_ (Month/Year). New! Students in year two beyond graduation are offered a special rate for 1 year.

Category	Electronic JEEG Available Online	Printed JEEG Mailed to You
<b>Student up to 1 Year Post Graduation</b>	\$ 0	\$90
<b>Student - Year Two Post Graduation (Grad Date: Mo/Yr.: ___/___)</b>	\$50	\$90



## Membership Renewal Developing World Category Qualification

If you reside in one of the countries listed below, you are eligible for EEGS's Developing World membership category rate of \$50.00 (or \$130.00 if you would like the printed, quarterly *Journal of Environmental & Engineering Geophysics (JEEG)* mailed to you). To receive a printed *JEEG* as a benefit of membership, select the Developing World Printed membership category on the membership application form.

Afghanistan	El Salvador	Maldives	Somalia
Albania	Eritrea	Mali	Sri Lanka
Algeria	Ethiopia	Marshall Islands	Sudan
Angola	Gambia	Mauritania	Suriname
Armenia	Georgia	Micronesia	Swaziland
Azerbaijan	Ghana	Moldova	Syria
Bangladesh	Guatemala	Mongolia	Taiwan
Belize	Guinea-Bissau	Morocco	Tajikistan
Benin	GuyanaHaiti	Mozambique	Tanzania
Bhutan	Honduras	Myanmar	Thailand
Bolivia	India	Nepal	Timor-Leste
Burkina Faso	Indonesia	Nicaragua	Togo
Burundi	Iran	Niger	Tonga
Cambodia	Iraq	Nigeria	Tunisia
Cameroon	Ivory Coast	North Korea	Turkmenistan
Cape Verde	Jordan	Pakistan	Uganda
Central African Republic	Kenya	Papua New Guinea	Ukraine
Chad	Kiribati	Paraguay	Uzbekistan
China	Kosovo	Philippines	Vanuatu
Comoros	Kyrgyz Republic	Rwanda	Vietnam
Congo, Dem. Rep.	Lao PDR	Samoa	West Bank and Gaza
Congo, Rep.	Lesotho	Sao Tome and Principe	Yemen
Djibouti	Liberia	Senegal	Zambia
Ecuador	Madagascar	Sierra Leone	Zimbabwe
Egypt	Malawi	Solomon Islands	

1720 South Bellaire Street | Suite 110 | Denver, CO 80222-4303

(p) 001.1.303.531.7517 | (f) 001.1.303.820.3844 | [staff@eegs.org](mailto:staff@eegs.org) | [www.eegs.org](http://www.eegs.org)



**CONTACT INFORMATION**

Salutation	First Name	Middle Initial	Last Name	
Company/Organization			Title	
Street Address	City	State/Province	Zip Code	Country
Direct Phone	Mobile Phone		Fax	
Email	Website			

**ABOUT ME: INTERESTS & EXPERTISE**

In order to identify your areas of specific interests and expertise, please check all that apply:

Role	Interest or Focus	Geophysical Expertise	Professional/ Scientific Societies	Willing to Serve on a Committee?
<input type="checkbox"/> Consultant	<input type="checkbox"/> Archaeology	<input type="checkbox"/> Borehole Geophysical Logging	<input type="checkbox"/> AAPG	<input type="checkbox"/> Publications
<input type="checkbox"/> User of Geophysical Svcs.	<input type="checkbox"/> Engineering	<input type="checkbox"/> Electrical Methods	<input type="checkbox"/> AEG	<input type="checkbox"/> Web Site
<input type="checkbox"/> Student	<input type="checkbox"/> Environmental	<input type="checkbox"/> Electromagnetics	<input type="checkbox"/> ASCE	<input type="checkbox"/> Membership
<input type="checkbox"/> Geophysical Contractor	<input type="checkbox"/> Geotechnical	<input type="checkbox"/> Gravity	<input type="checkbox"/> AWWA	<input type="checkbox"/> Student
<input type="checkbox"/> Equipment Manufacturer	<input type="checkbox"/> Geo. Infrastructure	<input type="checkbox"/> Ground Penetrating Radar	<input type="checkbox"/> AGU	
<input type="checkbox"/> Software Manufacturer	<input type="checkbox"/> Groundwater	<input type="checkbox"/> Magnetics	<input type="checkbox"/> EAGE	
<input type="checkbox"/> Research/Academia	<input type="checkbox"/> Hazardous Waste	<input type="checkbox"/> Marine Geophysics	<input type="checkbox"/> EERI	
<input type="checkbox"/> Government Agency	<input type="checkbox"/> Humanitarian Geo.	<input type="checkbox"/> Remote Sensing	<input type="checkbox"/> GeolInstitute	
<input type="checkbox"/> Other	<input type="checkbox"/> Mining	<input type="checkbox"/> Seismic	<input type="checkbox"/> GSA	
	<input type="checkbox"/> Shallow Oil & Gas	<input type="checkbox"/> Other	<input type="checkbox"/> NGWA	
	<input type="checkbox"/> UXO		<input type="checkbox"/> NSG	
	<input type="checkbox"/> Aerial Geophysics		<input type="checkbox"/> SEG	
	<input type="checkbox"/> Other		<input type="checkbox"/> SSA	
			<input type="checkbox"/> SPWLA	

1720 South Bellaire Street | Suite 110 | Denver, CO 80222-4303

(p) 001.1.303.531.7517 | (f) 000.1.303.820.3844 | [staff@eegs.org](mailto:staff@eegs.org) | [www.eegs.org](http://www.eegs.org)



**FOUNDATION CONTRIBUTIONS**

**FOUNDERS FUND**

The Founders Fund has been established to support costs associated with the establishment and maintenance of the EEGS Foundation as we solicit support from larger sponsors. These will support business office expenses, necessary travel, and similar expenses. It is expected that the operating capital for the foundation will eventually be derived from outside sources, but the Founder's Fund will provide an operation budget to "jump start" the work. Donations of \$50.00 or more are greatly appreciated. For additional information about the EEGS Foundation (an IRS status 501(c)(3) tax exempt public charity), visit the website at <http://www.EEGSFoundation.org>.

Foundation Fund Total: \$ \_\_\_\_\_

**STUDENT SUPPORT ENDOWMENT**

This Endowed Fund will be used to support travel and reduced membership fees so that we can attract greater involvement from our student members. Student members are the lifeblood of our society, and our support can lead to a lifetime of involvement and leadership in the near-surface geophysics community. Donations of \$50.00 or more are greatly appreciated. For additional information about the EEGS Foundation (a tax exempt public charity), visit the website at <http://www.EEGSFoundation.org>.

Student Support Endowment Total: \$ \_\_\_\_\_

**CORPORATE CONTRIBUTIONS**

The EEGS Foundation is designed to solicit support from individuals and corporate entities that are not currently corporate members (as listed above). We recognize that most of our corporate members are small businesses with limited resources, and that their contributions to professional societies are distributed among several organizations. The Corporate Founder's Fund has been developed to allow our corporate members to support the establishment of the Foundation as we solicit support from new contributors.

Corporate Contribution Total: \$ \_\_\_\_\_

Foundation Total: \$ \_\_\_\_\_

**Subtotals**

Membership: \$ \_\_\_\_\_

Student Sponsorship: \$ \_\_\_\_\_

Foundation Contributions: \$ \_\_\_\_\_

Grand Total: \$ \_\_\_\_\_

**PAYMENT INFORMATION**

- Check/Money Order     VISA     MasterCard
- AmEx     Discover

Card Number \_\_\_\_\_ Exp. Date \_\_\_\_\_ CVV #: \_\_\_\_\_

Name on Card \_\_\_\_\_

Signature \_\_\_\_\_

Make your check or money order in US dollars payable to: EEGS. Checks from Canadian bank accounts must be drawn on banks with US affiliations (example: checks from Canadian Credit Suisse banks are payable through Credit Suisse New York, USA). Checks must be drawn on US banks.

Payments are not tax deductible as charitable contributions although they may be deductible as a business expense. Consult your tax advisor.

Return this form with payment to: EEGS, 1720 South Bellaire Street, Suite 110, Denver, CO 80222 USA  
 Credit card payments can be faxed to EEGS at 001.1.303.820.3844

Corporate dues payments, once paid, are non-refundable. Individual dues are non-refundable except in cases of extreme hardship and will be considered on a case-by-case basis by the EEGS Board of Directors. Requests for refunds must be submitted in writing to the EEGS business office.

**QUESTIONS? CALL 001.1.303.531.7517**



EEGS is the premier organization for geophysics applied to engineering and environmental problems. Our multi-disciplinary blend of professionals from the private sector, academia, and government offers a unique opportunity to network with researchers, practitioners, and users of near-surface geophysical methods.

Memberships include access to the *Journal of Environmental & Engineering Geophysics (JEEG)*, proceedings archives of the Symposium on the Application of Geophysics to Engineering and Environmental Problems (SAGEEP), and our quarterly electronic newsletter *FastTIMES*. Members also enjoy complimentary access to SEG's technical program expanded abstracts as well as discounted SAGEEP registration fees, books and other educational publications. EEGS offers a variety of membership categories tailored to fit your needs. We strive to continuously add value to all the Corporate Membership categories. For the best value, we offer the Basic + Web ad Package Website Advertising opportunities. Please select (circle) your membership category and rate. EEGS is also offering an opportunity for all EEGS members to help support student(s) at \$20 each. Please indicate your willingness to contribute to support of student members below:

Yes, I wish to support \_\_\_ student(s) at \$20 each to be included in my membership payment.

Category	2016 Electronic JEEG	2016 Basic Rate (print JEEG)	2016 Basic + Web Ad Package
<p><b>Corporate Student Sponsor</b></p> <p><i>Includes one (1) individual membership, a company profile and linked logo on the EEGS Corporate Members web page, a company profile in FastTIMES and the SAGEEP program, recognition at SAGEEP and a 10% discount on advertising in JEEG and FastTIMES and Sponsorship of 10 student memberships</i></p>	\$310	\$340	\$840
<p><b>Corporate Donor</b></p> <p><i>Includes one (1) individual EEGS membership, one (1) full conference registration to SAGEEP, a company profile and linked logo on the EEGS Corporate Members web page, a company profile in FastTIMES and the SAGEEP program, recognition at SAGEEP and a 10% discount on advertising in JEEG and FastTIMES</i></p>	\$660	\$690	\$1190
<p><b>Corporate Associate</b></p> <p><i>Includes two (2) individual EEGS memberships, an exhibit booth and registration at SAGEEP, the ability to insert marketing materials in the SAGEEP delegate packets, a company profile and linked logo on the EEGS Corporate Members web page, a company profile in FastTIMES and the SAGEEP program, recognition at SAGEEP and a 10% discount on advertising in JEEG and FastTIMES</i></p>	\$2410	\$2440	\$2940
<p><b>Corporate Benefactor</b></p> <p><i>Includes two (2) individual memberships to EEGS, two (2) exhibit booths and registrations at SAGEEP, the ability to insert marketing materials in the SAGEEP delegate packets, a company profile and linked logo on the EEGS Corporate Members web page, a company profile in FastTIMES and the SAGEEP program, recognition at SAGEEP and a 10% discount on advertising in JEEG and FastTIMES</i></p>	\$4010	\$4040	\$4540
<p><b>Website Advertising</b></p> <p><i>One (1) Pop-Under, scrolling marquee style ad with tag line on Home page, logo linked to Company web site</i></p> <p><i>One (1) Button sized ad, linked logo, right rail on each web page</i></p>	\$600/yr. \$250/yr.	\$600/yr. \$250/yr.	Purchase Separately Package Rates include both website ad locations



**CONTACT INFORMATION**

Salutation	First Name	Middle Initial	Last Name	
Company/Organization			Title	
Street Address	City	State/Province	Zip Code	Country
Direct Phone	Mobile Phone		Fax	
Email	Website			

**ABOUT ME: INTERESTS & EXPERTISE**

In order to identify your areas of specific interests and expertise, please check all that apply:

Role	Interest or Focus	Geophysical Expertise	Professional/ Scientific Societies	Willing to Serve on a Committee?
<input type="checkbox"/> Consultant	<input type="checkbox"/> Archaeology	<input type="checkbox"/> Borehole Geophysical Logging	<input type="checkbox"/> AAPG	<input type="checkbox"/> Publications
<input type="checkbox"/> User of Geophysical Svcs.	<input type="checkbox"/> Engineering	<input type="checkbox"/> Electrical Methods	<input type="checkbox"/> AEG	<input type="checkbox"/> Web Site
<input type="checkbox"/> Student	<input type="checkbox"/> Environmental	<input type="checkbox"/> Electromagnetics	<input type="checkbox"/> ASCE	<input type="checkbox"/> Membership
<input type="checkbox"/> Geophysical Contractor	<input type="checkbox"/> Geotechnical	<input type="checkbox"/> Gravity	<input type="checkbox"/> AWWA	<input type="checkbox"/> Student
<input type="checkbox"/> Equipment Manufacturer	<input type="checkbox"/> Geo. Infrastructure	<input type="checkbox"/> Ground Penetrating Radar	<input type="checkbox"/> AGU	
<input type="checkbox"/> Software Manufacturer	<input type="checkbox"/> Groundwater	<input type="checkbox"/> Magnetics	<input type="checkbox"/> EAGE	
<input type="checkbox"/> Research/Academia	<input type="checkbox"/> Hazardous Waste	<input type="checkbox"/> Marine Geophysics	<input type="checkbox"/> EERI	
<input type="checkbox"/> Government Agency	<input type="checkbox"/> Humanitarian Geo.	<input type="checkbox"/> Remote Sensing	<input type="checkbox"/> Geolnstitute	
<input type="checkbox"/> Other	<input type="checkbox"/> Mining	<input type="checkbox"/> Seismic	<input type="checkbox"/> GSA	
	<input type="checkbox"/> Shallow Oil & Gas	<input type="checkbox"/> Other	<input type="checkbox"/> NGWA	
	<input type="checkbox"/> UXO		<input type="checkbox"/> NSG	
	<input type="checkbox"/> Aerial Geophysics		<input type="checkbox"/> SEG	
	<input type="checkbox"/> Other		<input type="checkbox"/> SSA	
			<input type="checkbox"/> SPWLA	

1720 South Bellaire Street | Suite 110 | Denver, CO 80222-4303  
 (p) 001.1.303.531.7517 | (f) 000.1.303.820.3844 | [staff@eegs.org](mailto:staff@eegs.org) | [www.eegs.org](http://www.eegs.org)



**FOUNDATION CONTRIBUTIONS**

**FOUNDERS FUND**

The Founders Fund has been established to support costs associated with the establishment and maintenance of the EEGS Foundation as we solicit support from larger sponsors. These will support business office expenses, necessary travel, and similar expenses. It is expected that the operating capital for the foundation will eventually be derived from outside sources, but the Founder's Fund will provide an operation budget to "jump start" the work. Donations of \$50.00 or more are greatly appreciated. For additional information about the EEGS Foundation (an IRS status 501(c)(3) tax exempt public charity), visit the website at <http://www.EEGSFoundation.org>.

Foundation Fund Total: \$ \_\_\_\_\_

**STUDENT SUPPORT ENDOWMENT**

This Endowed Fund will be used to support travel and reduced membership fees so that we can attract greater involvement from our student members. Student members are the lifeblood of our society, and our support can lead to a lifetime of involvement and leadership in the near-surface geophysics community. Donations of \$50.00 or more are greatly appreciated. For additional information about the EEGS Foundation (a tax exempt public charity), visit the website at <http://www.EEGSFoundation.org>.

Student Support Endowment Total: \$ \_\_\_\_\_

**CORPORATE CONTRIBUTIONS**

The EEGS Foundation is designed to solicit support from individuals and corporate entities that are not currently corporate members (as listed above). We recognize that most of our corporate members are small businesses with limited resources, and that their contributions to professional societies are distributed among several organizations. The Corporate Founder's Fund has been developed to allow our corporate members to support the establishment of the Foundation as we solicit support from new contributors.

Corporate Contribution Total: \$ \_\_\_\_\_

Foundation Total: \$ \_\_\_\_\_

**PAYMENT INFORMATION**

- Check/Money Order     VISA     MasterCard  
 AmEx     Discover

**Subtotals**

Membership: \$ \_\_\_\_\_

Student Sponsorship: \$ \_\_\_\_\_

Foundation Contributions: \$ \_\_\_\_\_

Grand Total: \$ \_\_\_\_\_

Card Number

Exp. Date

Name on Card

CVV#

Signature

Make your check or money order in US dollars payable to: EEGS. Checks from Canadian bank accounts must be drawn on banks with US affiliations (example: checks from Canadian Credit Suisse banks are payable through Credit Suisse New York, USA). Checks must be drawn on US banks.

Payments are not tax deductible as charitable contributions although they may be deductible as a business expense. Consult your tax advisor.

Return this form with payment to: EEGS, 1720 South Bellaire Street, Suite 110, Denver, CO 80222 USA  
 Credit card payments can be faxed to EEGS at 001.1.303.820.3844

Corporate dues payments, once paid, are non-refundable. Individual dues are non-refundable except in cases of extreme hardship and will be considered on a case-by-case basis by the EEGS Board of Directors. Requests for refunds must be submitted in writing to the EEGS business office.

**QUESTIONS? CALL 001.1.303.531.7517**

# EEGS CORPORATE MEMBERS

## Corporate Benefactor

Your Company Here!

Geostuff

[www.geostuff.com](http://www.geostuff.com)

Northwest Geophysics

[www.northwestgeophysics.com](http://www.northwestgeophysics.com)

## Corporate Associate

Advanced Geosciences, Inc.

[www.agiusa.com](http://www.agiusa.com)

GeoVista Ltd.

[www.geovista.co.uk](http://www.geovista.co.uk)

Quality Geosciences Company, LLC

[www.quality-geophysics.com](http://www.quality-geophysics.com)

Allied Associates Geophysical Ltd.

[www.allied-associates.co.uk](http://www.allied-associates.co.uk)

Interpex Ltd.

[www.interpex.com](http://www.interpex.com)

Spotlight Geophysical Services

[www.spotlightgeo.com](http://www.spotlightgeo.com)

CGG Canada Services Ltd.

[www.cgg.com](http://www.cgg.com)

Mount Sopris Instruments

[www.mountsopris.com](http://www.mountsopris.com)

## Corporate Student Sponsor

Geo Solutions Limited, Inc.

[www.geosolutionsltd.com](http://www.geosolutionsltd.com)

Exploration Instruments LLC

[www.expins.com](http://www.expins.com)

Ontash & Ermac, Inc.

[www.ontash.com](http://www.ontash.com)

Spotlight Geophysical Services

[www.spotlightgeo.com](http://www.spotlightgeo.com)

Geogiga Technology Corporation

[www.geogiga.com](http://www.geogiga.com)

Petros Eikon Incorporated

[www.petroseikon.com](http://www.petroseikon.com)

R. T. Clark Co. Inc.

[www.rtclark.com](http://www.rtclark.com)

Geomar Software Inc.

[www.geomar.com](http://www.geomar.com)

Sensors & Software Inc.

[www.sensoft.ca](http://www.sensoft.ca)

Geometrics, Inc.

[www.geometrics.com](http://www.geometrics.com)

Vista Clara Inc.

[www.vista-clara.com](http://www.vista-clara.com)

Geonics Ltd.

[www.geonics.com](http://www.geonics.com)

Zonge international, Inc

[www.zonge.com](http://www.zonge.com)

Geophysical Survey Systems, Inc.

[www.geophysical.com](http://www.geophysical.com)

## Corporate Donor

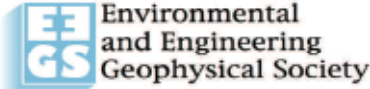
Geosoft Inc.

[www.geosoft.com](http://www.geosoft.com)

Geomatrix Earth Science Ltd.

[www.geomatrix.co.uk](http://www.geomatrix.co.uk)

# EEGS STORE



## 2015 Publications Order Form

ALL ORDERS ARE PREPAY

1720 S. Bellaire Street, Suite 110  
 Denver, CO 80222-4303  
 Phone: 303.531.7517; Fax: 303.820.3844  
 E-mail: [staff@eegs.org](mailto:staff@eegs.org); Web Site: [www.eeegs.org](http://www.eeegs.org)

**Sold To:**  
 Name: \_\_\_\_\_  
 Company: \_\_\_\_\_  
 Address: \_\_\_\_\_  
 City/State/Zip: \_\_\_\_\_  
 Country: \_\_\_\_\_ Phone: \_\_\_\_\_  
 E-mail: \_\_\_\_\_ Fax: \_\_\_\_\_

**Ship To (If different from "Sold To"):**  
 Name: \_\_\_\_\_  
 Company: \_\_\_\_\_  
 Address: \_\_\_\_\_  
 City/State/Zip: \_\_\_\_\_  
 Country: \_\_\_\_\_ Phone: \_\_\_\_\_  
 E-mail: \_\_\_\_\_ Fax: \_\_\_\_\_

**Instructions:** Please complete both pages of this order form and fax or mail the form to the EEGS office listed above. Payment must accompany the form or materials will not be shipped. Faxing a copy of a check does not constitute payment and the order will be held until payment is received. Purchase orders will be held until payment is received. If you have questions regarding any of the items, please contact the EEGS Office. Thank you for your order!

### SAGEEP PROCEEDINGS

			Member/Non-Member	
	0036	2014 (CD-ROM)	\$75	\$100
	0034	2013 (CD-ROM)	\$75	\$100
	0033	2012 (CD-ROM)	\$75	\$100
	0030	2011 (CD-ROM)	\$75	\$100
	0029	2010 (CD-ROM)	\$75	\$100
	0026	2009 (CD-ROM)	\$75	\$100
	0025	2008 (CD-ROM)	\$75	\$100
	0023	2007 (CD-ROM)	\$75	\$100

			Member/Non-Member	
	0020	2006 (CD-ROM)	\$75	\$100
	0018	2005 (CD-ROM)	\$75	\$100
	0016	2004 (CD-ROM)	\$75	\$100
	0015	2003 (CD-ROM)	\$75	\$100
	0014	2002 (CD-ROM)	\$75	\$100
	0013	2001 (CD-ROM)	\$75	\$100
	0012	1988-2000 (CD-ROM)	\$150	\$225
<b>SUBTOTAL—PROCEEDINGS ORDERED:</b>				

### SAGEEP Short Course Handbooks

	0039	2013 Agricultural Geophysics: Methods Employed and Recent Applications - Barry Allred, Bruce Smith, et al.	\$35	\$45
	0038	2010 Processing Seismic Refraction Tomography Data (including CD-ROM) - William Doll	\$35	\$45
	0037	2011 Application of Time Domain Electromagnetics to Ground-water Studies - David V. Fitterman	\$20	\$30
	0032	2010 Application of Time Domain Electromagnetics to Ground-water Studies - David V. Fitterman	\$20	\$30
	0027	2010 Principles and Applications of Seismic Refraction Tomography (Printed Course Notes & CD-ROM) - William Doll	\$70	\$90
	0028	2009 Principles and Applications of Seismic Refraction Tomography (CD-ROM w/ PDF format Course Notes) - William Doll	\$70	\$90
	0007	2002 - UXO 101 - An Introduction to Unexploded Ordnance - (Dwain Butler, Roger Young, William Veith)	\$15	\$25
	0009	2001 - Applications of Geophysics in Geotechnical and Environmental Engineering (HANDBOOK ONLY) - John Greenhouse	\$25	\$35
	0011	2001 - Applications of Geophysics in Environmental Investigations (CD-ROM ONLY) - John Greenhouse	\$80	\$105
	0010	2001- Applications of Geophysics in Geotechnical and Environmental Engineering (HANDBOOK) & Applications of Geophysics in Environmental Investigations (CD-ROM) - John Greenhouse	\$100	\$125
	0004	1998 - Global Positioning System (GPS): Theory and Practice - John D. Bossler & Dorota A. Brzezinska	\$10	\$15
	0003	1998 - Introduction to Environmental & Engineering Geophysics - Roelof Versteeg	\$10	\$15
	0002	1998 - Near Surface Seismology - Don Steeples	\$10	\$15
	0001	1998 - Nondestructive Testing (NDT) - Larry Olson	\$10	\$15
	0005	1997 - An Introduction to Near-Surface and Environmental Geophysical Methods and Applications - Roelof Versteeg	\$10	\$15
	0006	1996 - Introduction to Geophysical Techniques and their Applications for Engineers and Project Managers - Richard Benson & Lynn Yuhr	\$10	\$15

### Miscellaneous Items

	0031	<b>New Pricing!!</b> Advances in Near-surface Seismology and Ground Penetrating Radar—R. Miller, J. Bradford, K. Holliger Special Pricing Available for Limited Time—through March 25, 2015—end of SAGEEP 2015!	\$79	\$99
	0021	Geophysics Applied to Contaminant Studies: Papers Presented at SAGEEP from 1988-2006 (CD-ROM)	\$50	\$75
	0022	Application of Geophysical Methods to Engineering and Environmental Problems - Produced by SEGJ	\$35	\$45
	0019	Near Surface Geophysics - 2005 Dwain K. Butler, Ed.; Hardcover Special student rate - \$71.20	\$89	\$139
	0035	Einstein Redux: A Humorous & Refreshing New Chapter in the Einstein Saga—D. Butler	\$20	\$25

MISCELLANEOUS ITEMS CONTINUED ON NEXT PAGE...

# EEGS STORE

Publications Order Form (Page Two)

		EEGS T-shirt (X-Large) Please circle: white/gray	\$10	\$10
		EEGS Lapel Pin	\$3	\$3
<b>SUBTOTAL—SHORT COURSE/MISC. ORDERED ITEMS:</b>				

**Journal of Environmental and Engineering Geophysics (JEEG) Back Issue Order Information:**

**Member Rate: \$15 | Non-Member Rate: \$25**

Qt.	Year	Issue	Qt.	Year	Issue	Qt.	Year	Issue
	1995	JEEG 0/1 - July		2004	JEEG 9/1 - March		2009	JEEG 14/1 - March
		JEEG 0/2 - January			JEEG 9/2 - June			JEEG 14/2 - June
	1996	JEEG 1/1 - April			JEEG 9/3 - September			JEEG 14/3 - September
		JEEG 1/2 - August			JEEG 9/4 - December			JEEG 14/4 - December
		JEEG 1/3 - December		2005	JEEG 10/1 - March		2010	JEEG 15/1 - March
	1998	JEEG 3/2 - June			JEEG 10/2 - June			JEEG 15/2 - June
		JEEG 3/3 - September			JEEG 10/3 - September			JEEG 15/3 - September
		JEEG 3/4 - December			JEEG 10/4 - December			JEEG 15/4 - December
	1999	JEEG 4/1 - March		2006	JEEG 11/1 - March		2011	JEEG 16/1 - March
		JEEG 4/2 - June			JEEG 11/2 - June			JEEG 16/2 - June
		JEEG 4/3 - September			JEEG 11/3 - September			JEEG 16/3 - September
		JEEG 4/4 - December			JEEG 11/4 - December			JEEG 16/4 - December
	2000	JEEG 5/3 - September		2007	JEEG 12/1 - March		2012	JEEG 17/1 - March
		JEEG 5/4 - December			JEEG 12/2 - June			JEEG 17/2 - June
	2001	JEEG 6/1 - March			JEEG 12/3 - September			JEEG 17/3 - September
		JEEG 6/3 - September			JEEG 12/4 - December			JEEG 17/4 - December
		JEEG 6/4 - December		2008	JEEG 13/1 - March		2013	JEEG 18/1 - March
	2003	JEEG 8/1 - March			JEEG 13/2 - June			JEEG 18/2 - June
		JEEG 8/2 - June			JEEG 13/3 - September			JEEG 18/3 - September
		JEEG 8/3 - September			JEEG 13/4 - December			JEEG 18/4 - December
		JEEG 8/4 - December					2014	JEEG 19/1 - March
								JEEG 19/2 - June
<b>SUBTOTAL—JEEG ISSUES ORDERED</b>								

SUBTOTAL - SAGEEP PROCEEDINGS ORDERED	
SUBTOTAL - SHORT COURSE / MISCELLANEOUS ITEMS ORDERED	
SUBTOTAL - JEEG ISSUES ORDERED	
CITY & STATE SALES TAX (If order will be delivered in the Denver, Colorado—add an additional 7.62%)	
SHIPPING & HANDLING (US—\$10; Canada/Mexico—\$20; All other countries: \$45)	
<b>GRAND TOTAL:</b>	

Order Return Policy: Returns for credit must be accompanied by invoice or invoice information (invoice number, date, and purchase price). Materials must be in saleable condition. Out-of-print titles are not accepted 180 days after order. No returns will be accepted for credit that were not purchased directly from EEGS. Return shipment costs will be borne by the shipper. Returned orders carry a 10% restocking fee to cover administrative costs unless waived by EEGS.

**Payment Information:**

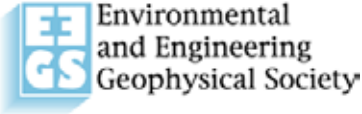
- Check #: \_\_\_\_\_ (Payable to EEGS)
- Purchase Order: \_\_\_\_\_  
(Shipment will be made upon receipt of payment.)
- Visa    MasterCard    AMEX    Discover

**Important Payment Information:** Checks from Canadian bank accounts must be drawn on banks with US affiliations (example: checks from Canadian Credit Suisse banks are payable through Credit Suisse New York, USA). If you are unsure, please contact your bank. As an alternative to paying by check, we recommend sending money orders or paying by credit card.

Card Number: \_\_\_\_\_ CVV# \_\_\_\_\_  
Exp. Date: \_\_\_\_\_

Cardholder Name (Print) \_\_\_\_\_  
Signature: \_\_\_\_\_

# EEGS STORE



1720 S. Bellaire Street, Suite 110  
 Denver, CO 80222-4303  
 Phone: 303.531.7517  
 Fax: 303.820.3844  
 E-mail: [staff@eegs.org](mailto:staff@eegs.org)  
 Web Site: [www.eegs.org](http://www.eegs.org)

## 2016 Merchandise Order Form

**ALL ORDERS ARE PREPAY**

**Sold To:**

Name: \_\_\_\_\_  
 Company: \_\_\_\_\_  
 Address: \_\_\_\_\_  
 City/State/Zip: \_\_\_\_\_  
 Country: \_\_\_\_\_ Phone: \_\_\_\_\_  
 E-mail: \_\_\_\_\_ Fax: \_\_\_\_\_

**Ship To** (If different from "Sold To"):

Name: \_\_\_\_\_  
 Company: \_\_\_\_\_  
 Address: \_\_\_\_\_  
 City/State/Zip: \_\_\_\_\_  
 Country: \_\_\_\_\_ Phone: \_\_\_\_\_  
 E-mail: \_\_\_\_\_ Fax: \_\_\_\_\_

**Instructions:** Please complete this order form and fax or mail the form to the EEGS office listed above. Payment must accompany the form or materials will not be shipped. Faxing a copy of a check does not constitute payment and the order will be held until payment is received. Purchase orders will be held until payment is received. If you have questions regarding any of the items, please contact the EEGS Office. Thank you for your order!

**Merchandise Order Information:**

ITEM DESCRIPTION	QTY	EEGS T-SHIRT COLOR WHITE OR GRAY/Size	MEMBER RATE	NON- MEMBER RATE	TOTAL
EEGS Mug			\$10	\$10	
SAGEEP 2015 T-shirt (Small)			\$18	\$18	
SAGEEP 2015 T-shirt (Medium)			\$18	\$18	
SAGEEP 2015 T-shirt (Large)			\$18	\$18	
SAGEEP 2015 T-shirt (XLarge)			\$18	\$18	
SAGEEP 2015 T-shirt (XXLarge)			\$18	\$18	
EEGS T-shirt (Gray: L, M & XLarge; White: L & XL)			\$10	\$10	
EEGS Lapel Pin			\$3	\$3	
<b>SUBTOTAL – MERCHANDISE ORDERED:</b>					


**TOTAL ORDER:**

SUBTOTAL – Merchandise Ordered:	
STATE SALES TAX: (If order will be delivered in Colorado – add 3.7000%):	
CITY SALES TAX: (If order will be delivered in the City of Denver – add an additional 3.5000%):	
SHIPPING AND HANDLING (US - \$7; Canada/Mexico - \$15; All other countries - \$40):	
<b>GRAND TOTAL:</b>	


**Payment Information:**

- Check #: \_\_\_\_\_ (Payable to EEGS)
- Purchase Order: \_\_\_\_\_  
 (Shipment will be made upon receipt of payment.)
- Visa  MasterCard  AMEX  Discover

Three easy ways to order:

 Fax to: 303.820.3844

 Internet: [www.eegs.org](http://www.eegs.org)

 Mail to: EEGS  
 1720 S. Bellaire St., #110  
 Denver, CO 80222-4303

Card Number: \_\_\_\_\_ CVV# \_\_\_\_\_ Cardholder Name (Print): \_\_\_\_\_

Exp. Date: \_\_\_\_\_ Signature: \_\_\_\_\_

**THANK YOU FOR YOUR ORDER!**

Order Return Policy: Returns for credit must be accompanied by invoice or invoice information (invoice number, date, and purchase price). Materials must be in saleable condition. Out-of-print titles are not accepted 180 days after order. No returns for credit will be accepted which were not purchased directly from EEGS. Return shipment costs will be borne by the shipper. Returned orders carry a 10% restocking fee to cover administrative costs unless waived by EEGS.